

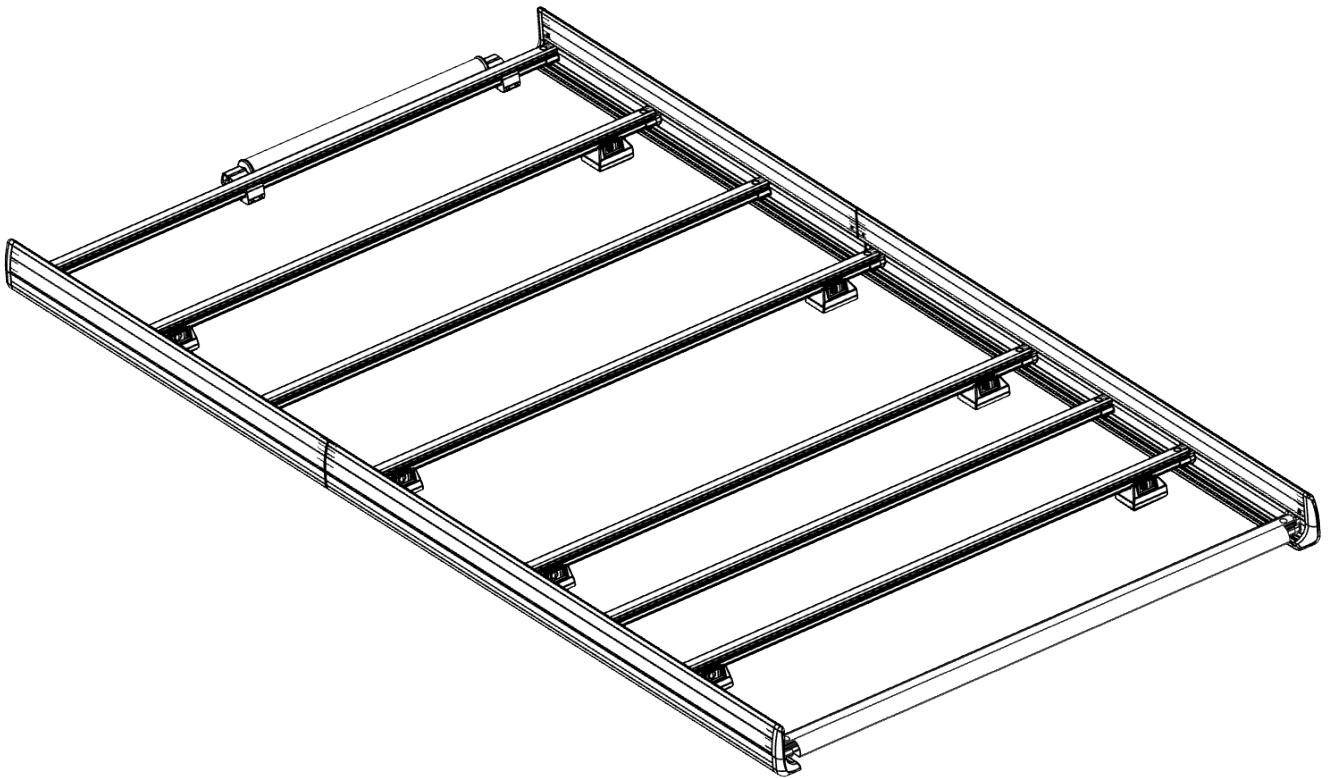





POLAIRE



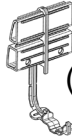
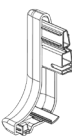

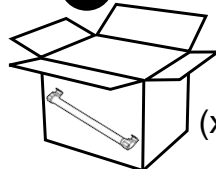
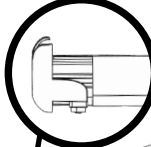
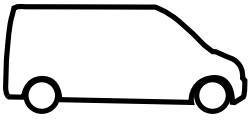
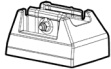
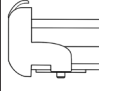
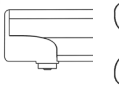
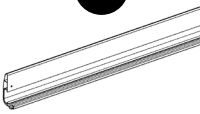
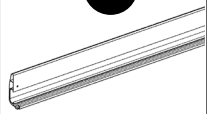



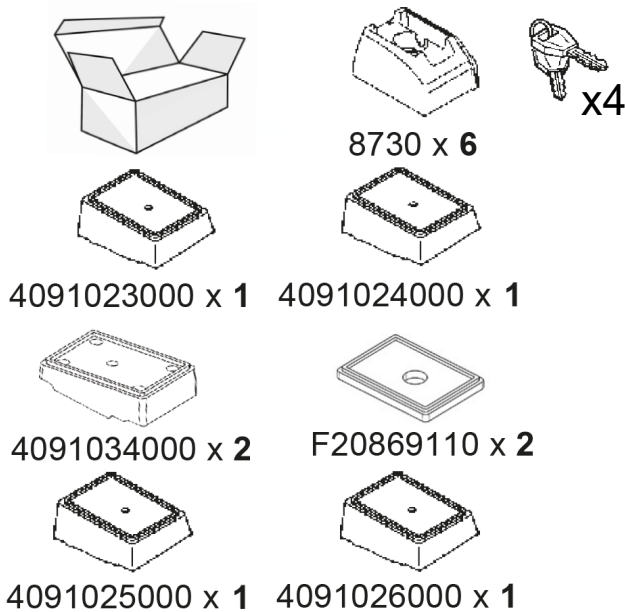

EZY RACK



FR	Instructions de montage
EN	Installation instructions
IT	Istruzioni per il montaggio
ES	Istrucciones de montaje
PT	Instruções de montagem
NL	Inbouwhandleiding
DE	Einbauanleitung
PL	Instrukcja wbudowania
DK	Monteringsveiledning

E1  (x8) M6x12	E2  (x8) Q M6	E5  (x2)	E6  (x2)	E7  (x2)	E10  (x1)	E13  (x1)
	E9 	E11 	E12 	E3 	E4 	E8 
Berlingo L1	x 6	1538 cm x 3	1538 cm x 4	1070 cm x 2	1313 cm x 2	16
Partner L1						
Combo L1						
Doblo L1						
Proace City L1						



5505607000	F20072180
 M8x75 mm x2	 x1
 M8x55 mm x2	 8606 x12
 M8x60 mm x2	 M8x45 mm x6
 Ø8,2x14 x6	 M8 x6
 Ø8,4x16 x6	
 Cod. 8600 x6	
 x1	

DONNEES SYSTEME DE PORTAGE

Type : Ezy-Rack STLA S 2018 > L1

Dimension galerie 2383x1538

Masse galerie 24 kg

Masse max. sur galerie 131 kg

Mass max. galerie chargée 155 kg

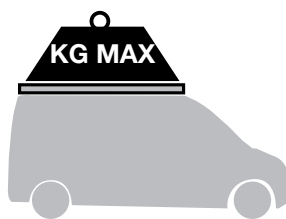

DONNÉES VEHICULE

Masse max. sur galerie

Berlingo, Partner, Proace city (L1, VU ou 5 places) 120 kg

Berlingo, Partner, Proace city (L1, 7 places) 70 kg

Combo, Doblo (L1, Vu ou 5 places) 126 kg

Combo, Doblo (L1, 7 places) 76 kg

ATTENTION : merci de contrôler dans le carnet de bord du véhicule la masse maximale admissible sur la galerie ou le toit.
Si la notice de bord indique la charge maximale admise sur le toit, la masse max. sur galerie s'obtient de retranchant la masse de la galerie

PGEP-001A

PGEA-B54A



PGEP-001A
2025-05-06

L1 : BERLINGO 2018 -> / COMBO 2019 -> / DOBLO 2022->
PARTNER 2018 -> / PROACE CITY 2019 ->

2/16

Y3F2831A01

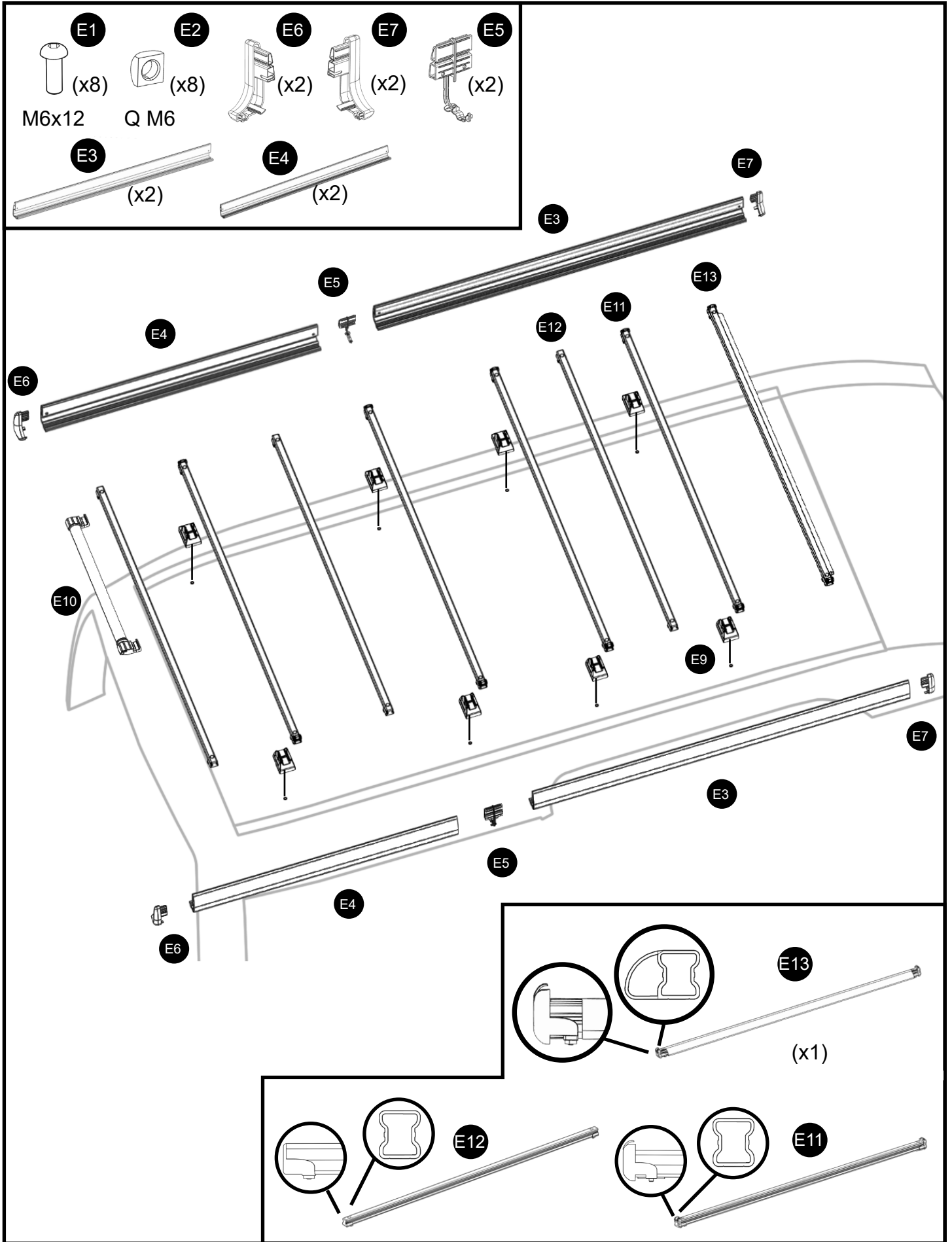

PGEP-001A
2025-05-06

L1 : BERLINGO 2018 -> / COMBO 2019 -> / DOBLO 2022->
PARTNER 2018 ->/ PROACE CITY 2019 ->

3/16

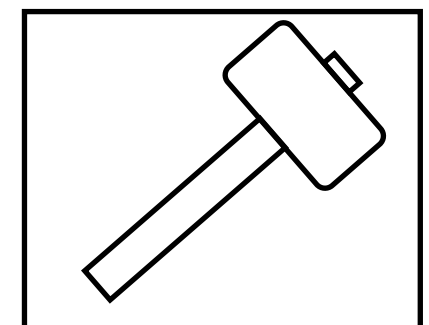
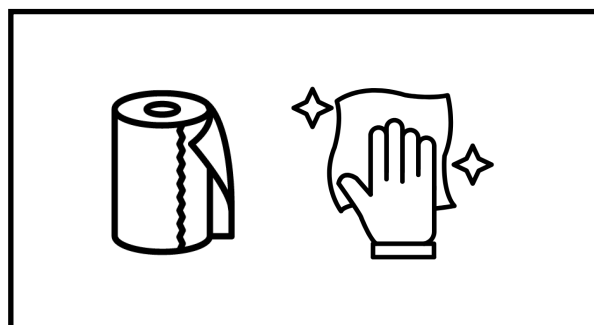
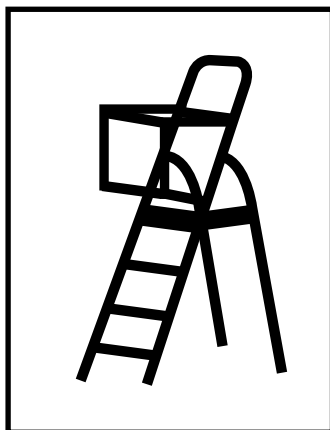
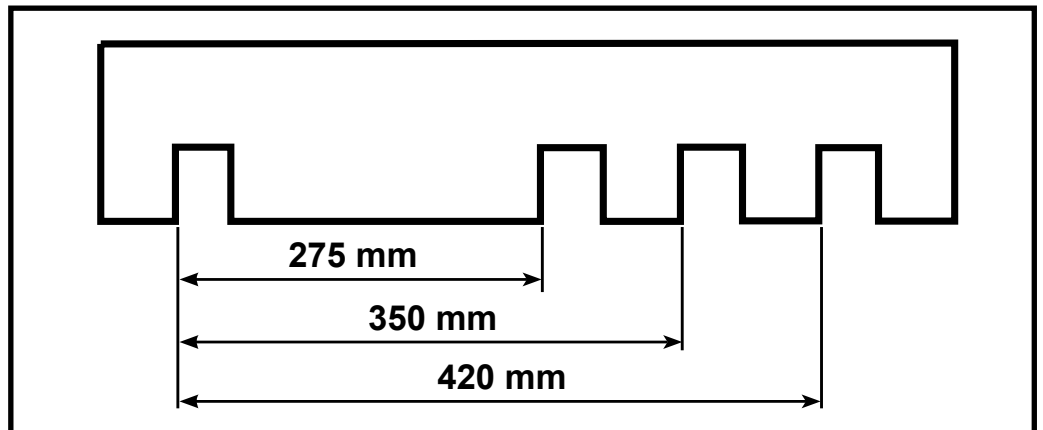
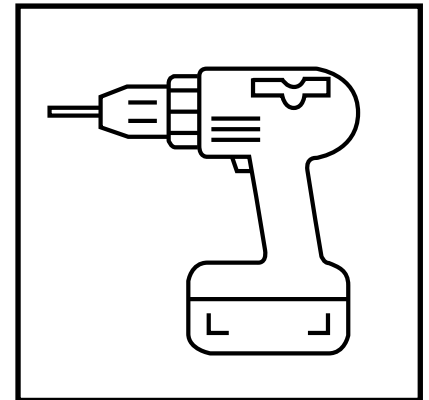
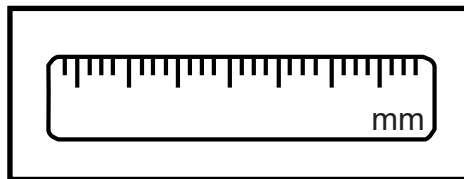
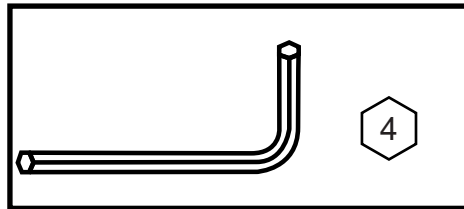
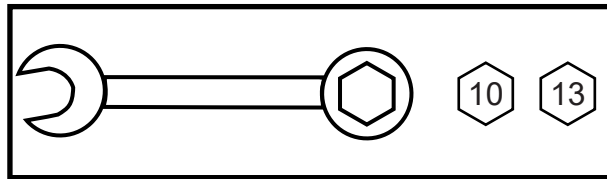
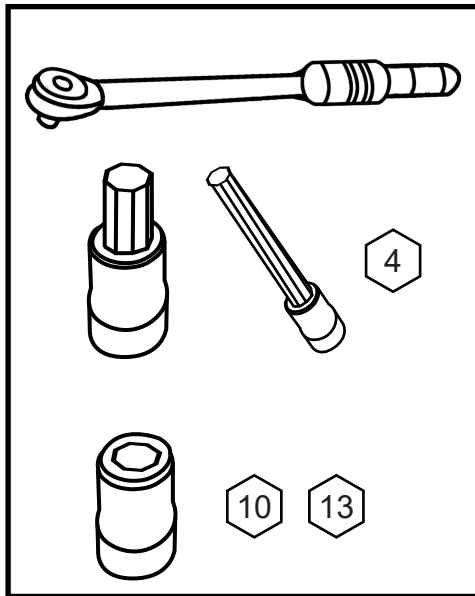

AV

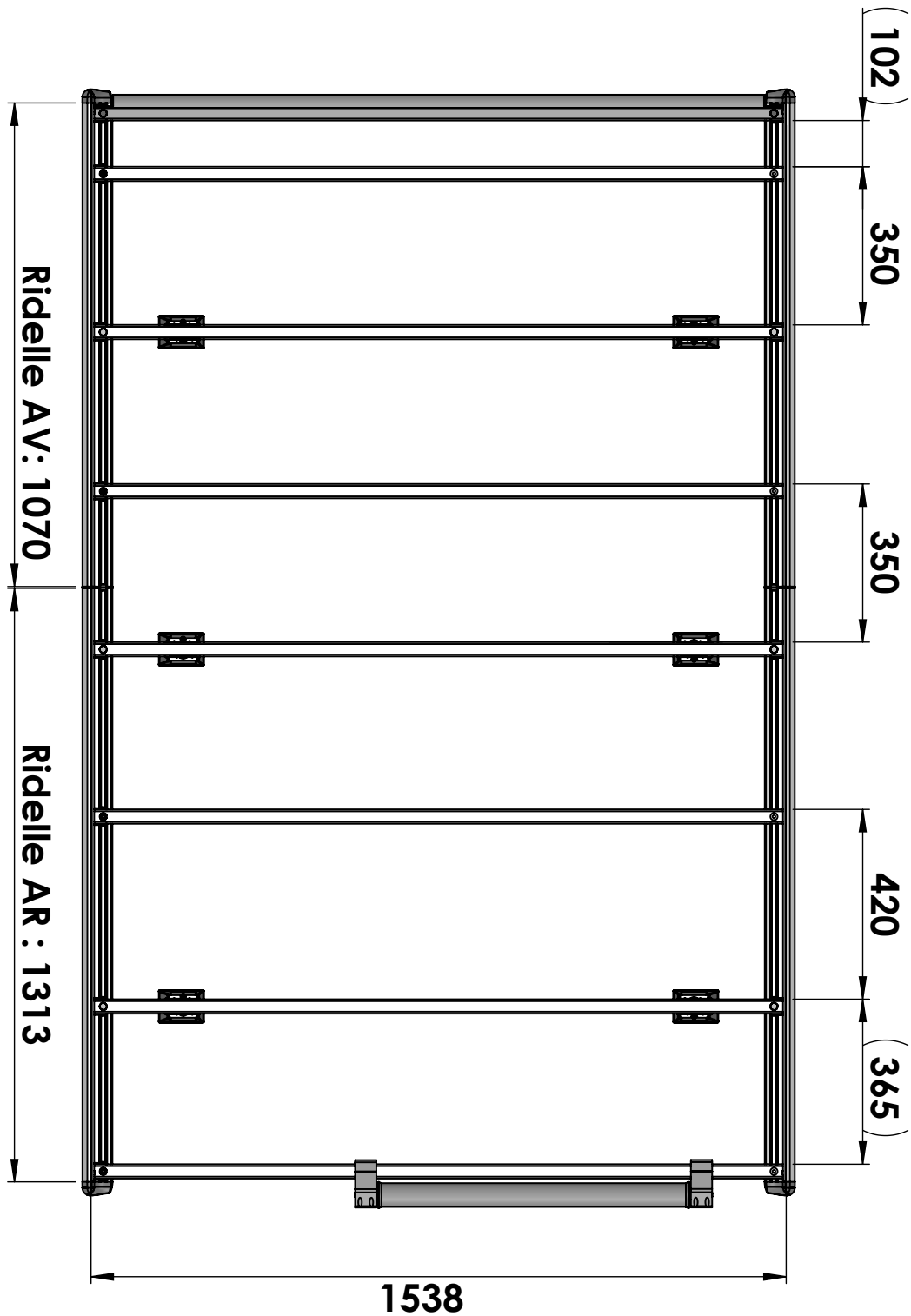

AR

PGEP-001A
2025-05-06

L1 : BERLINGO 2018 -> / COMBO 2019 -> / DOBLO 2022->
PARTNER 2018 ->/ PROACE CITY 2019 ->

5/16

Y3F2831A01

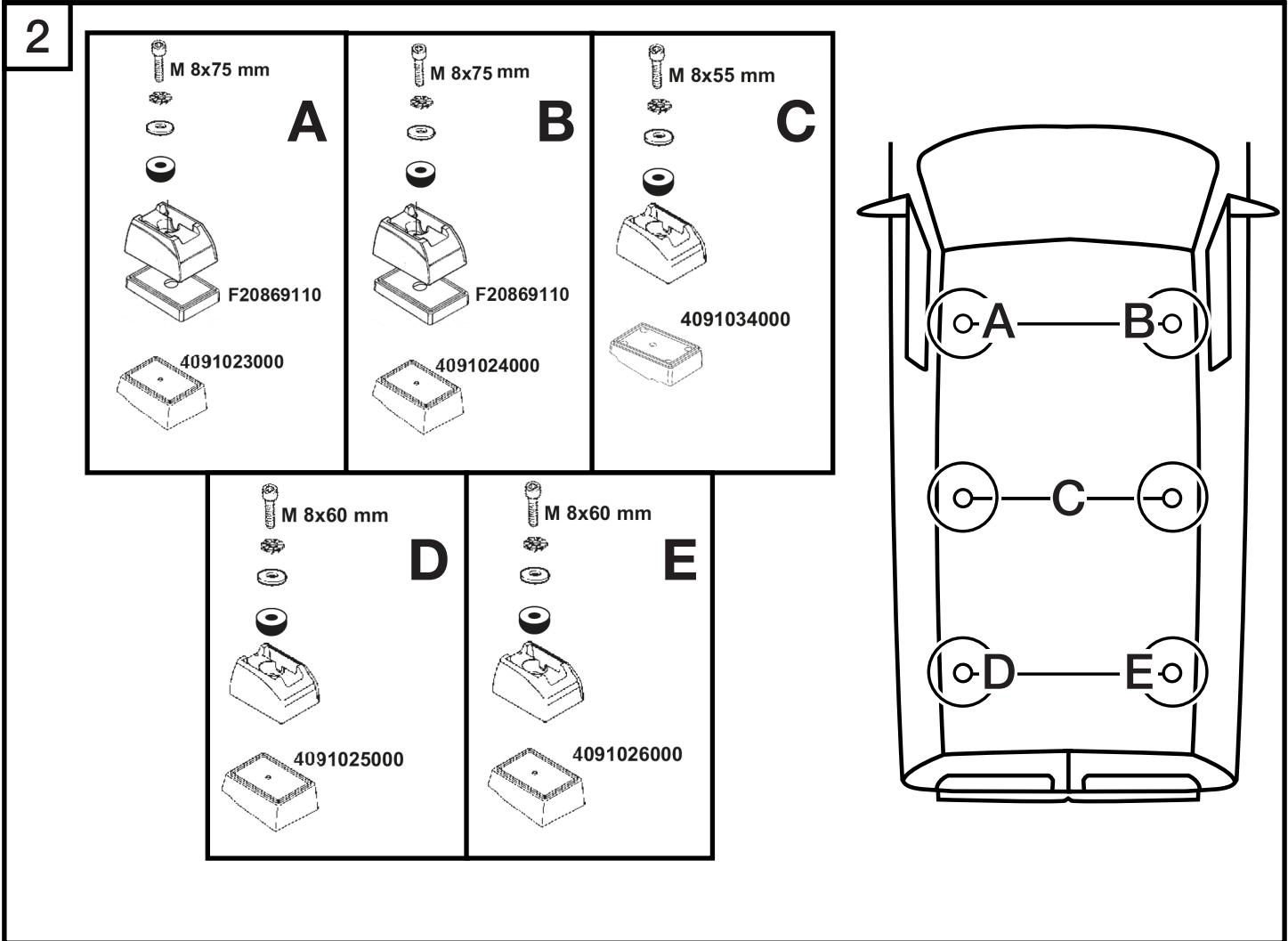
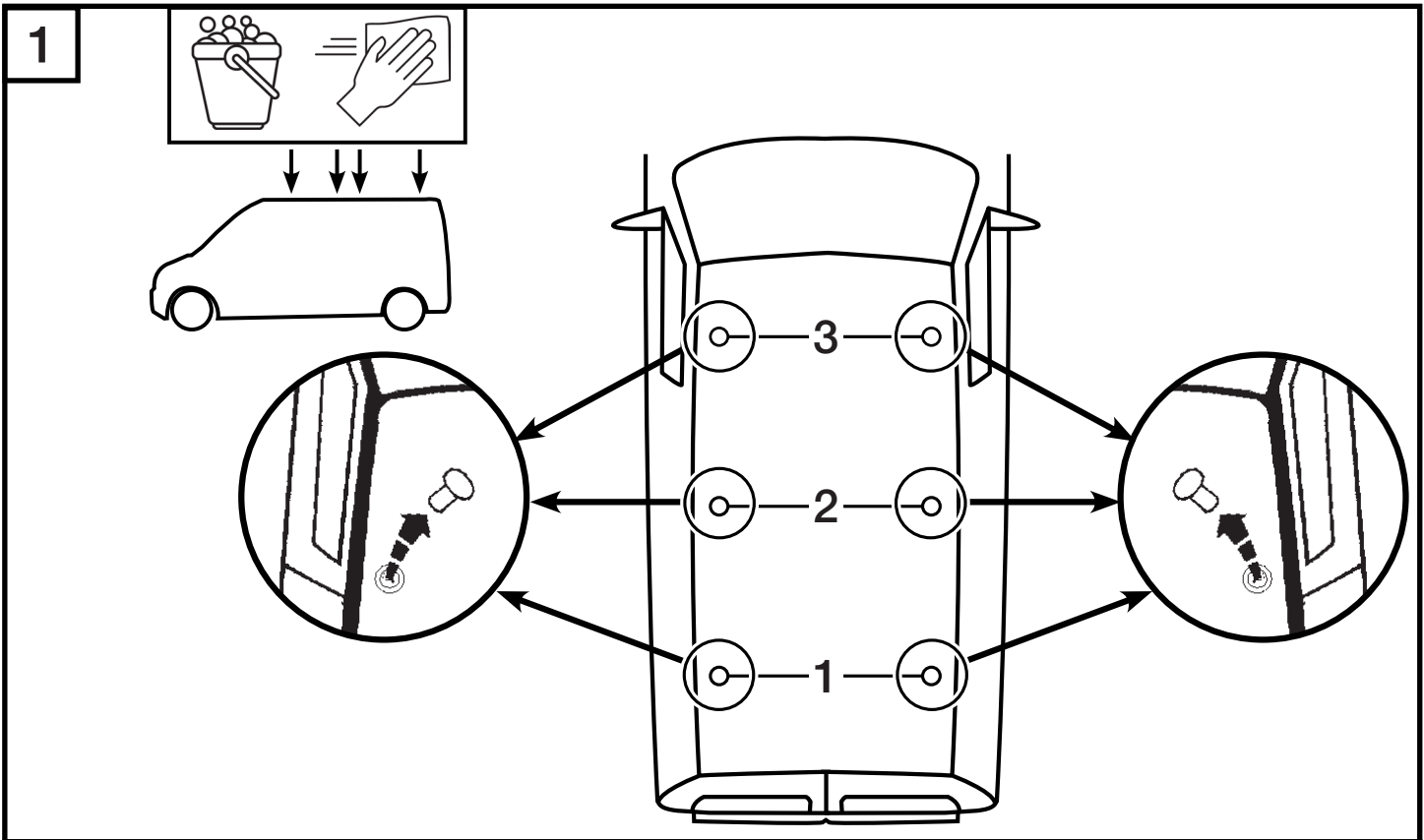

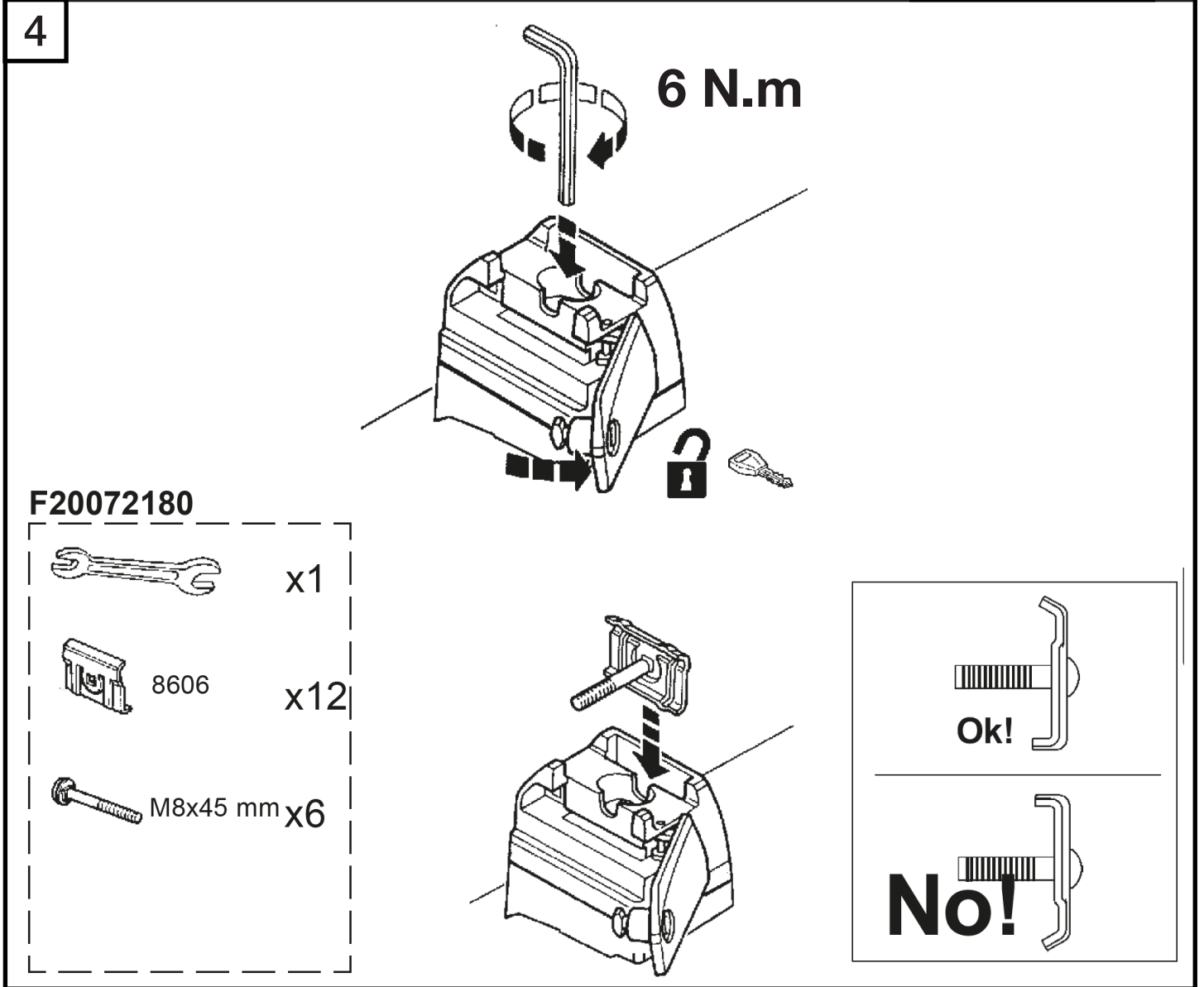
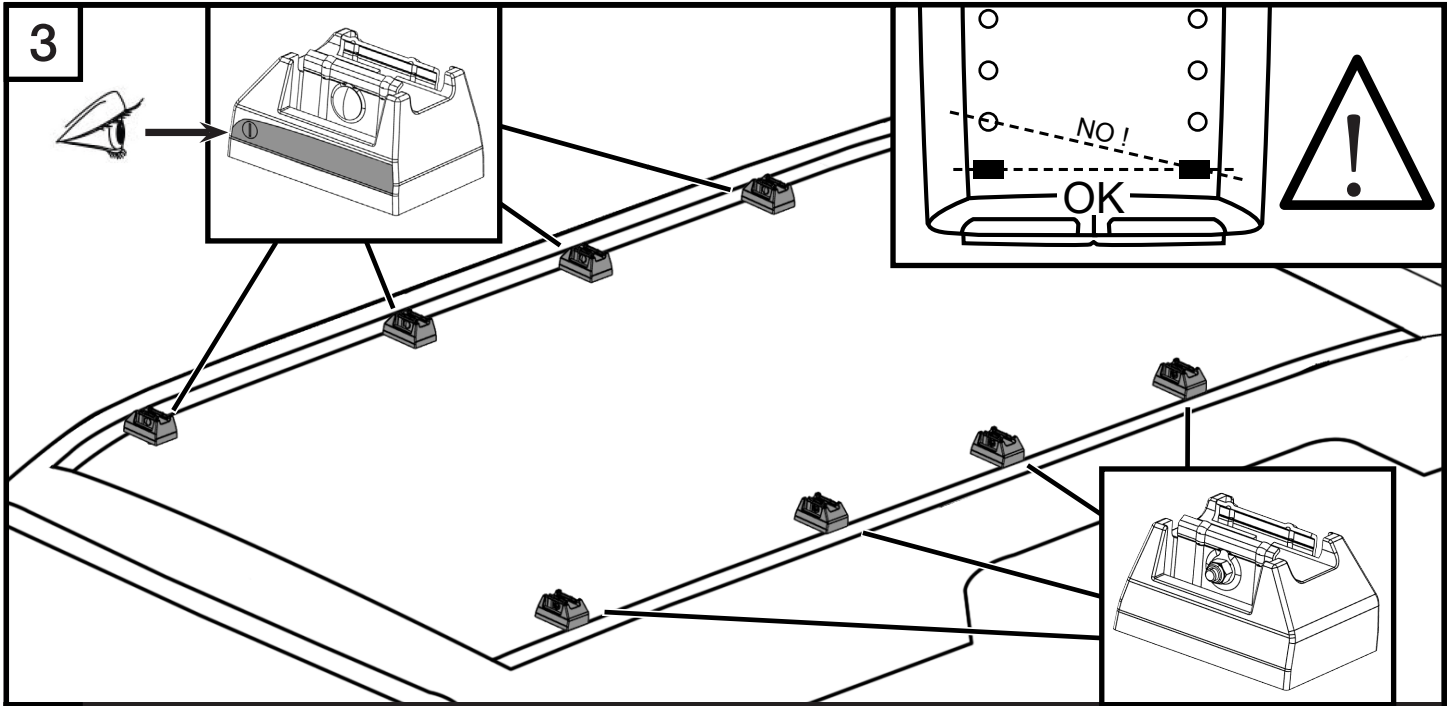

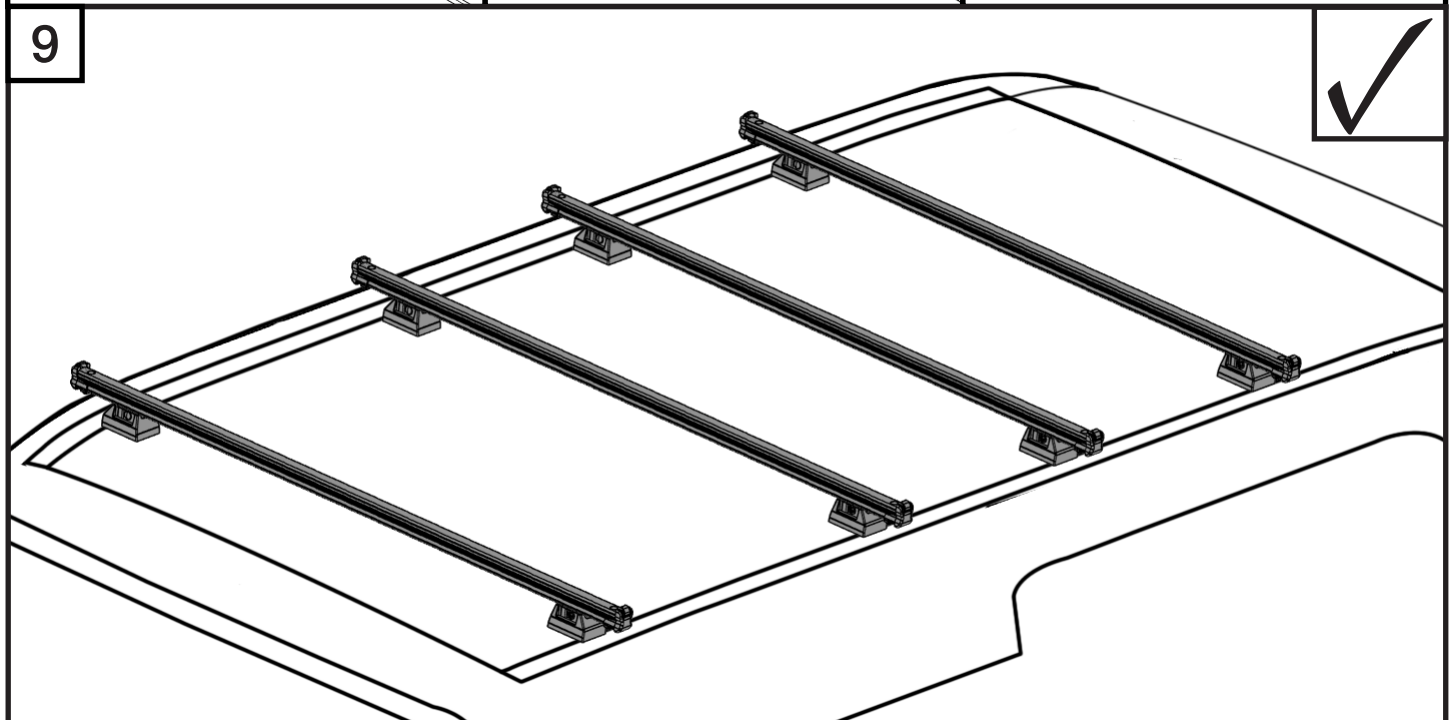
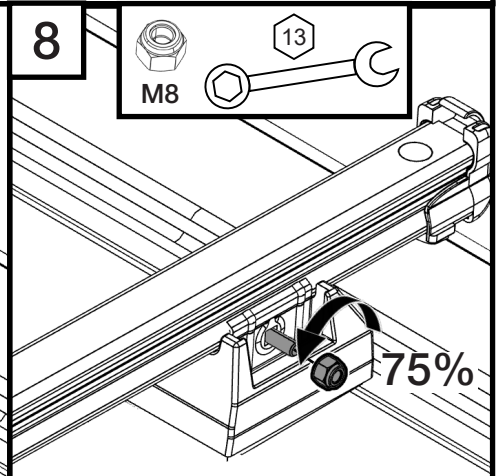
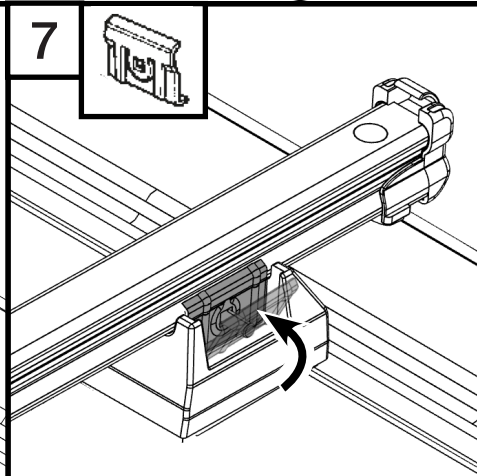
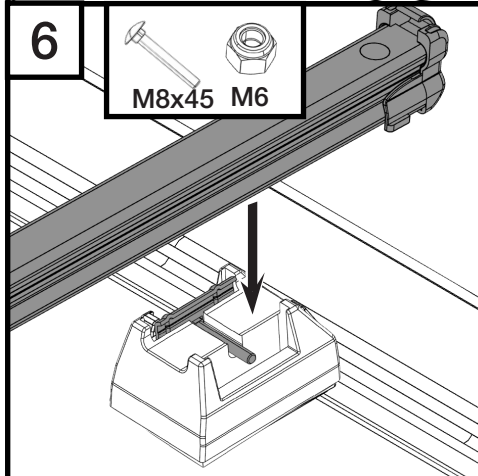
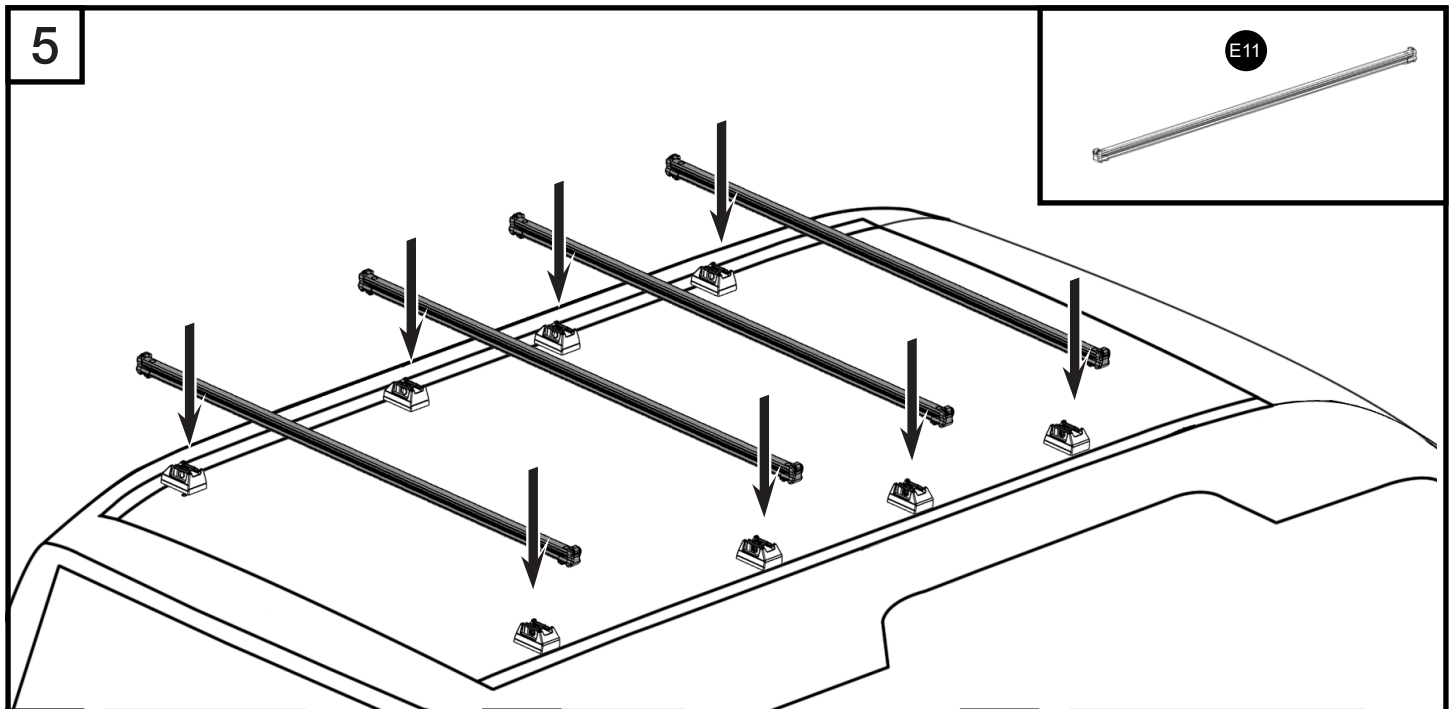

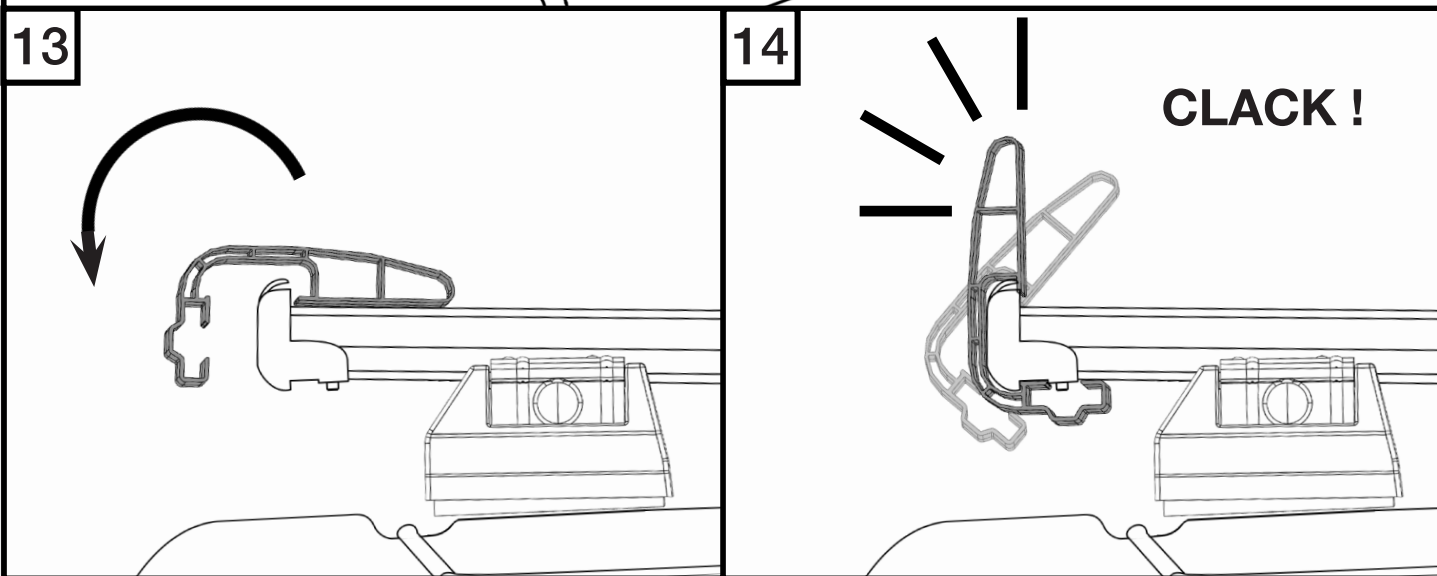
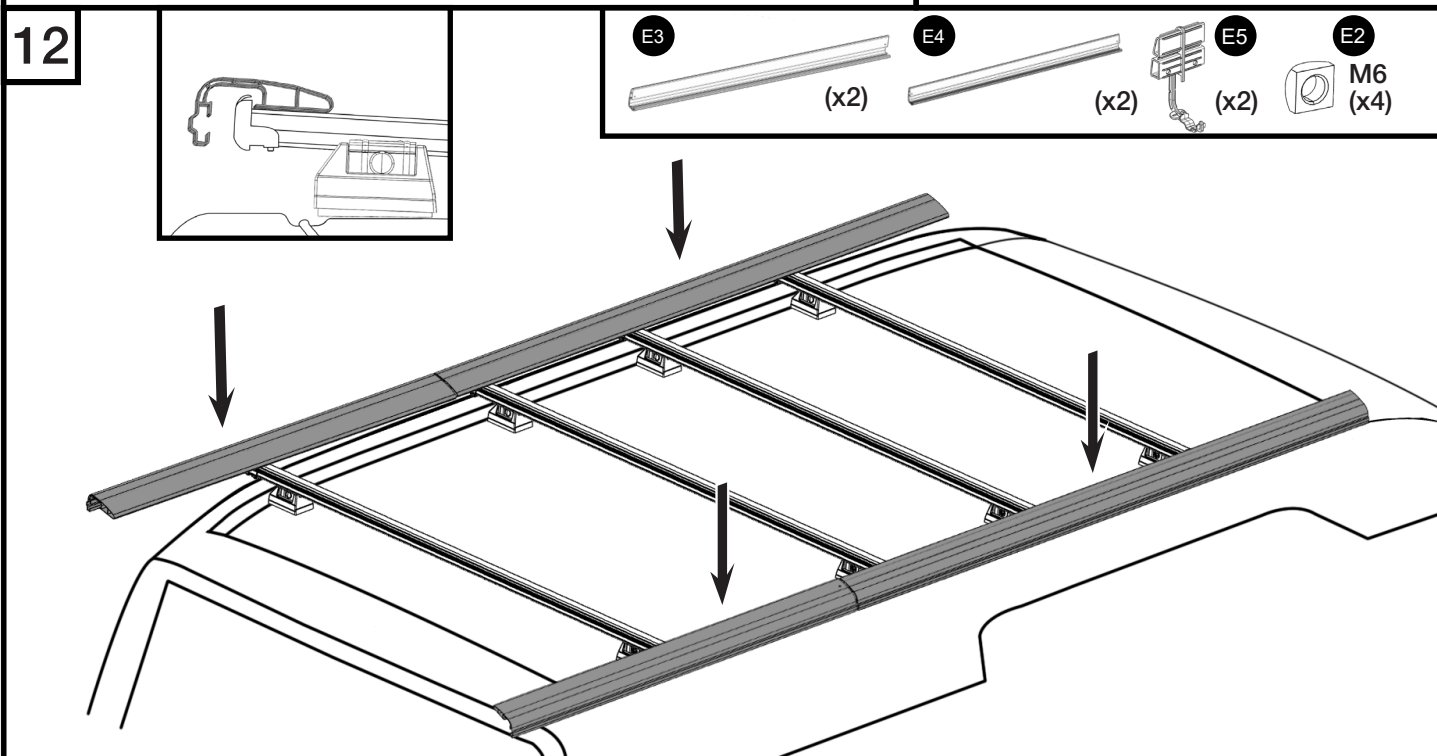
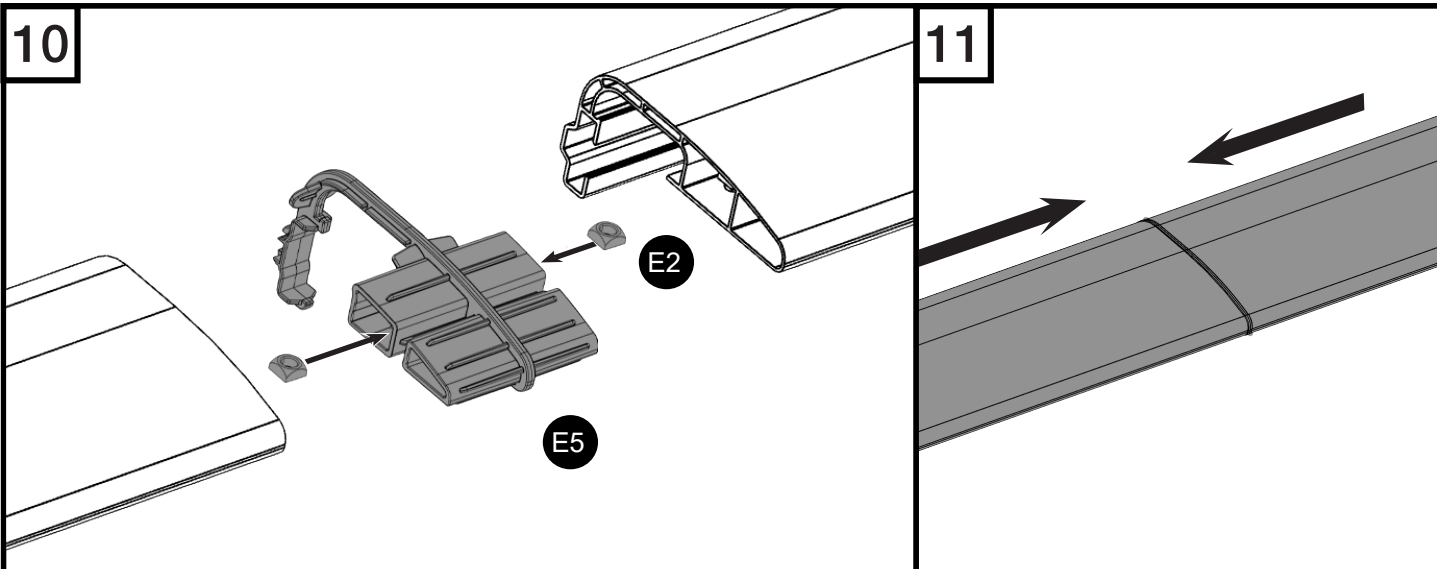

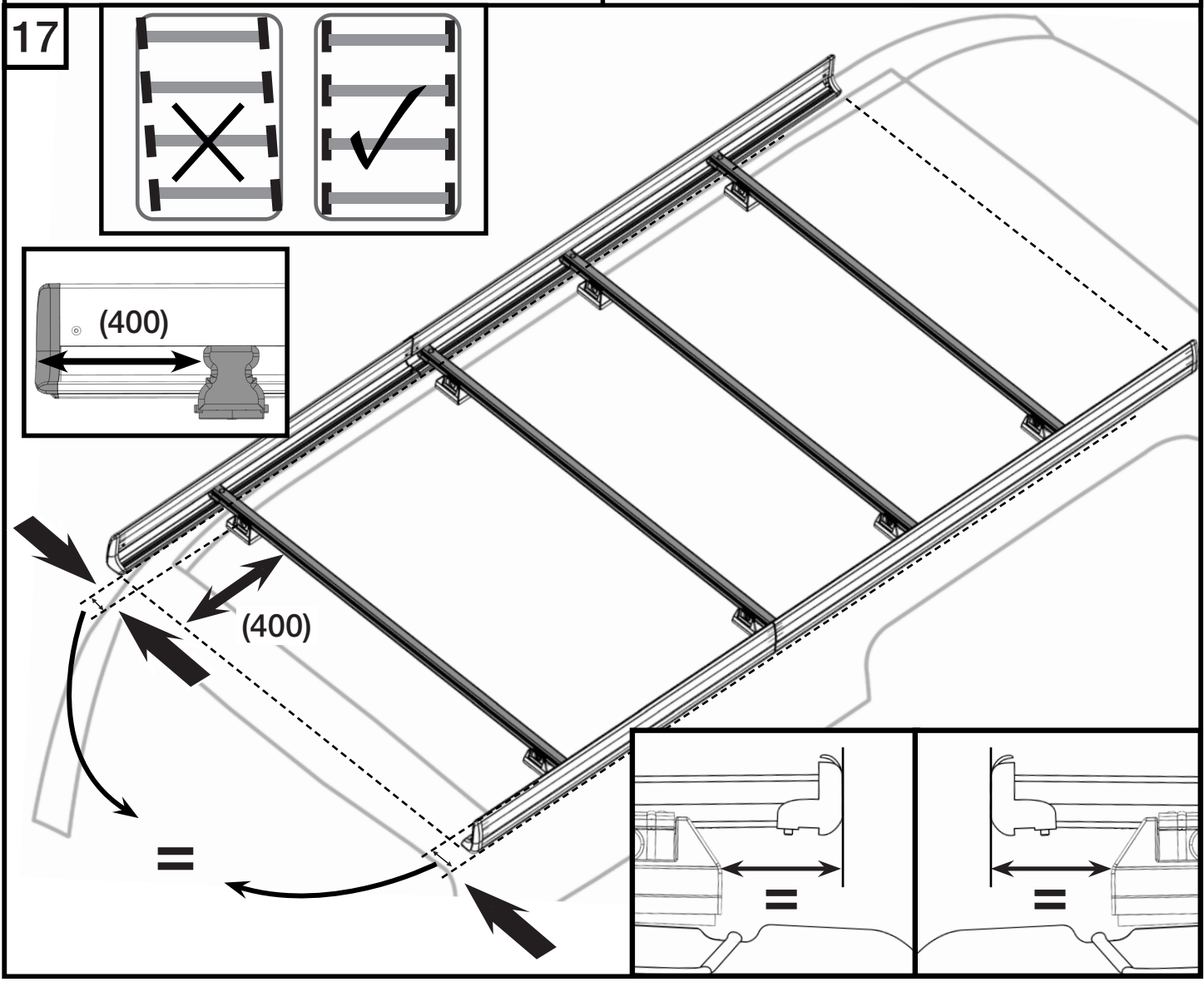
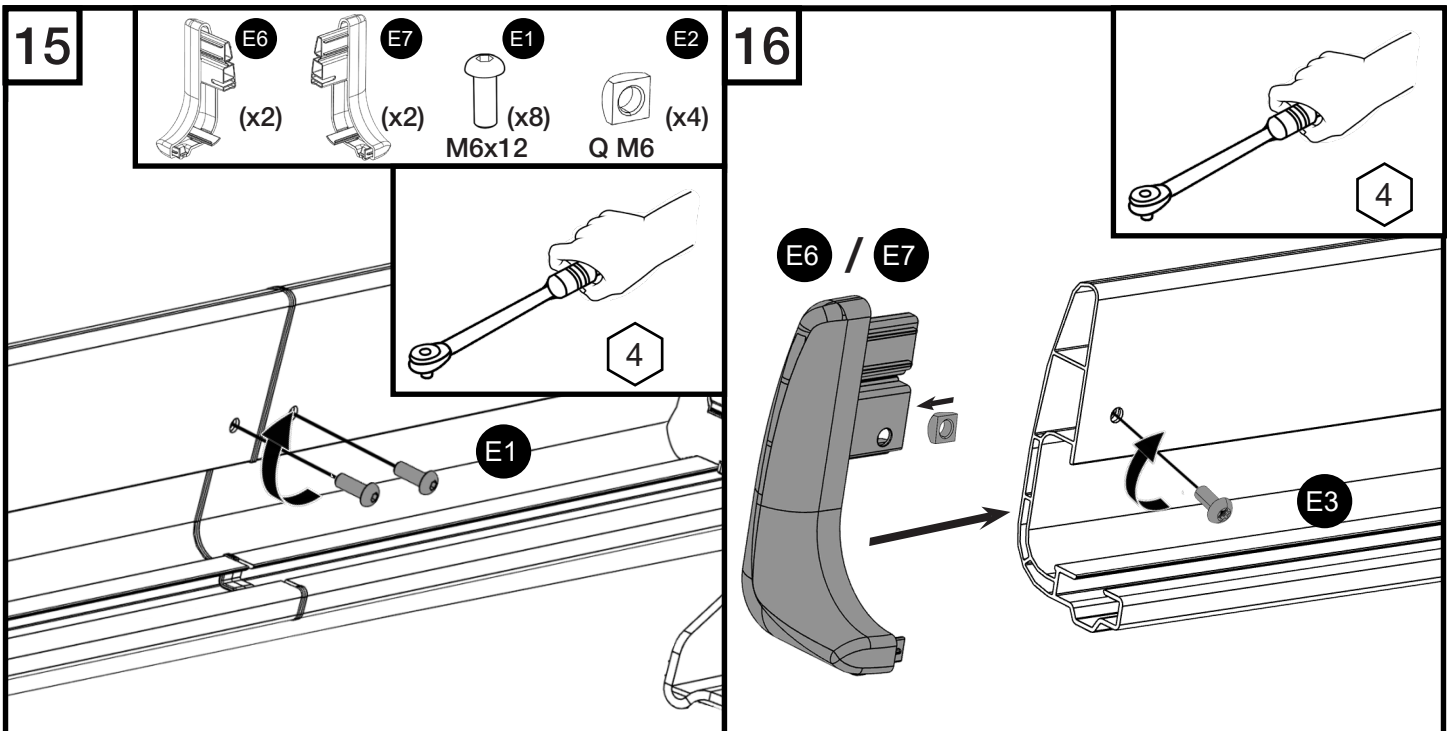

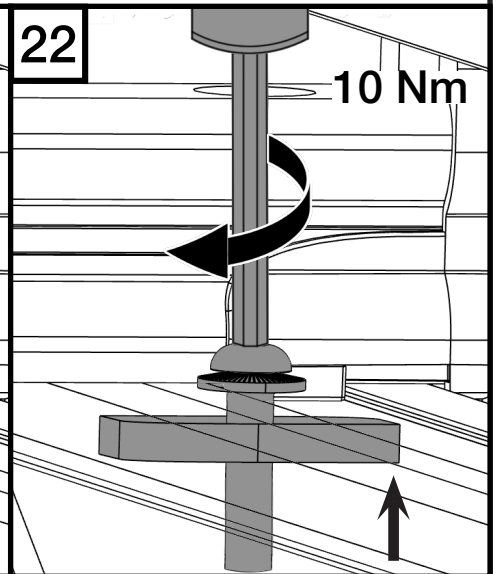
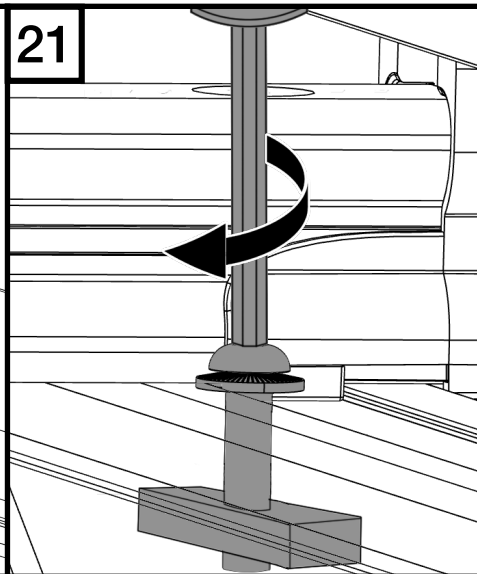
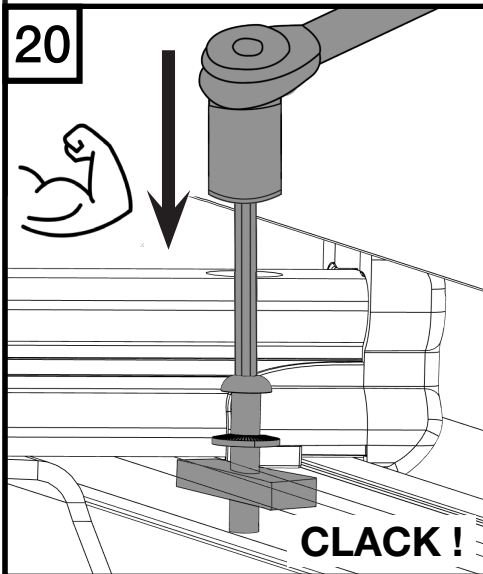
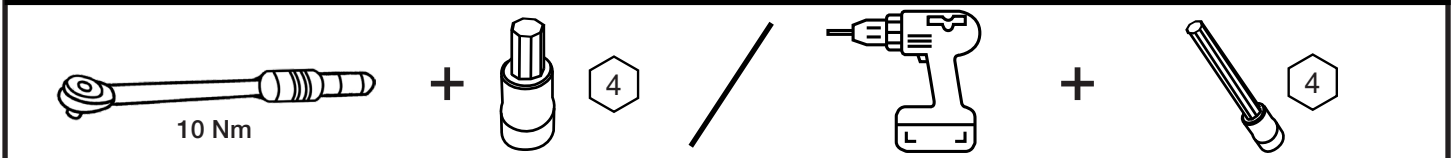
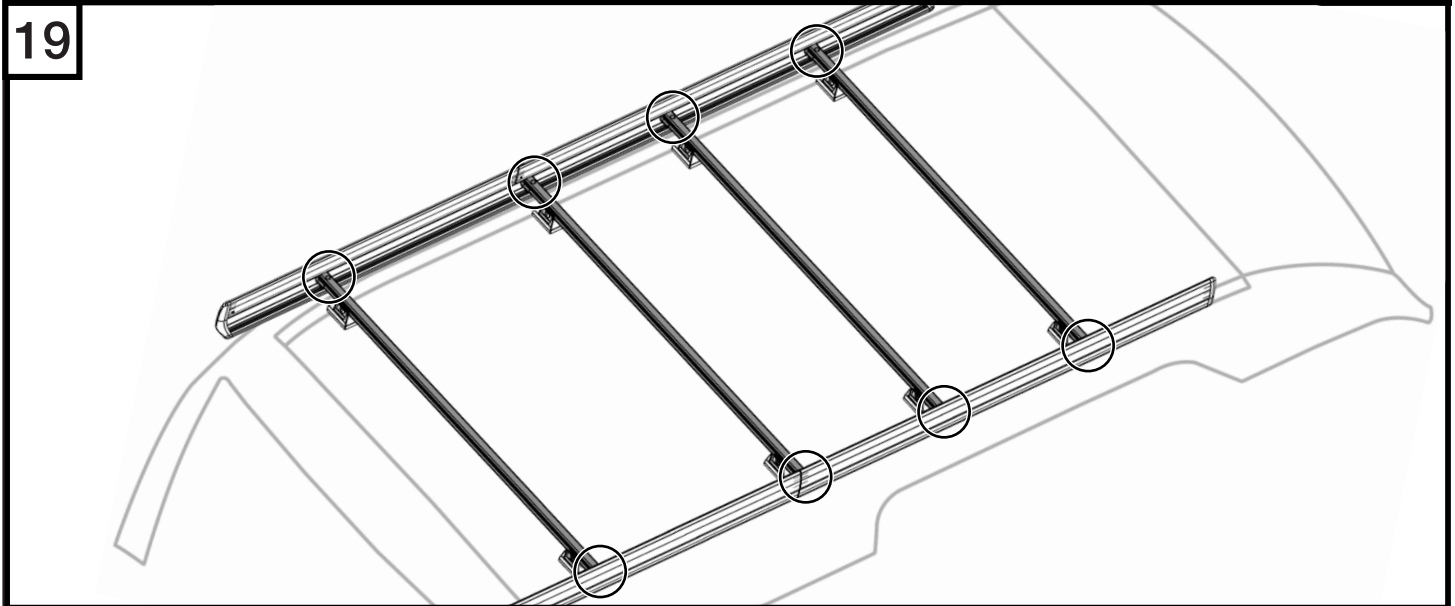
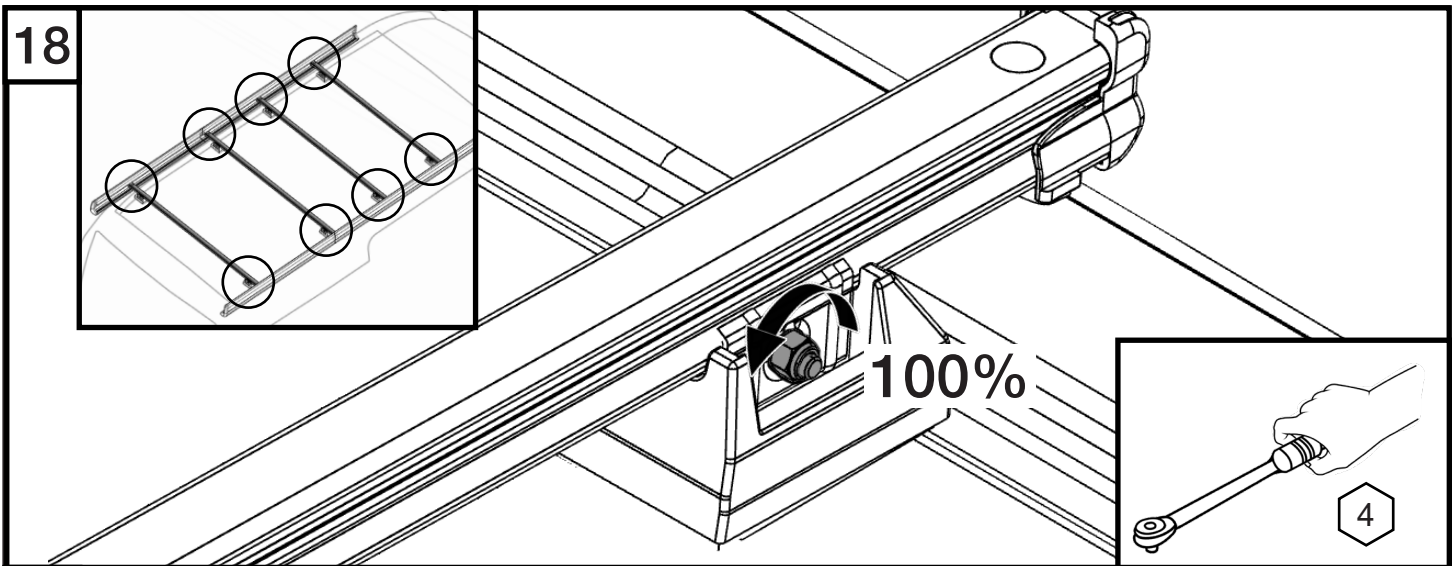

23

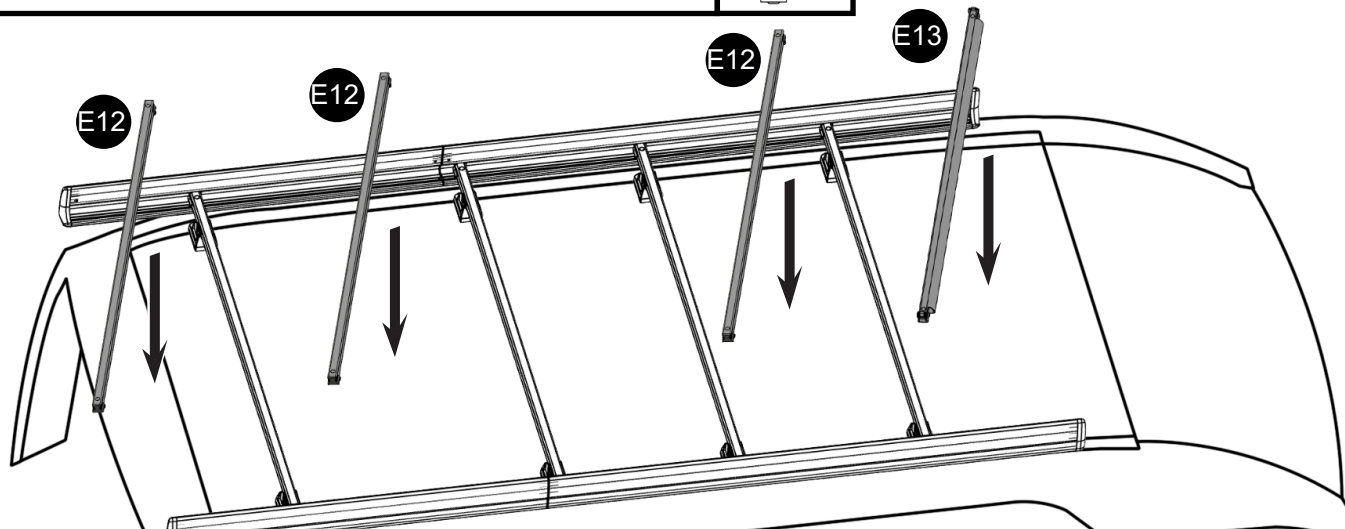

24

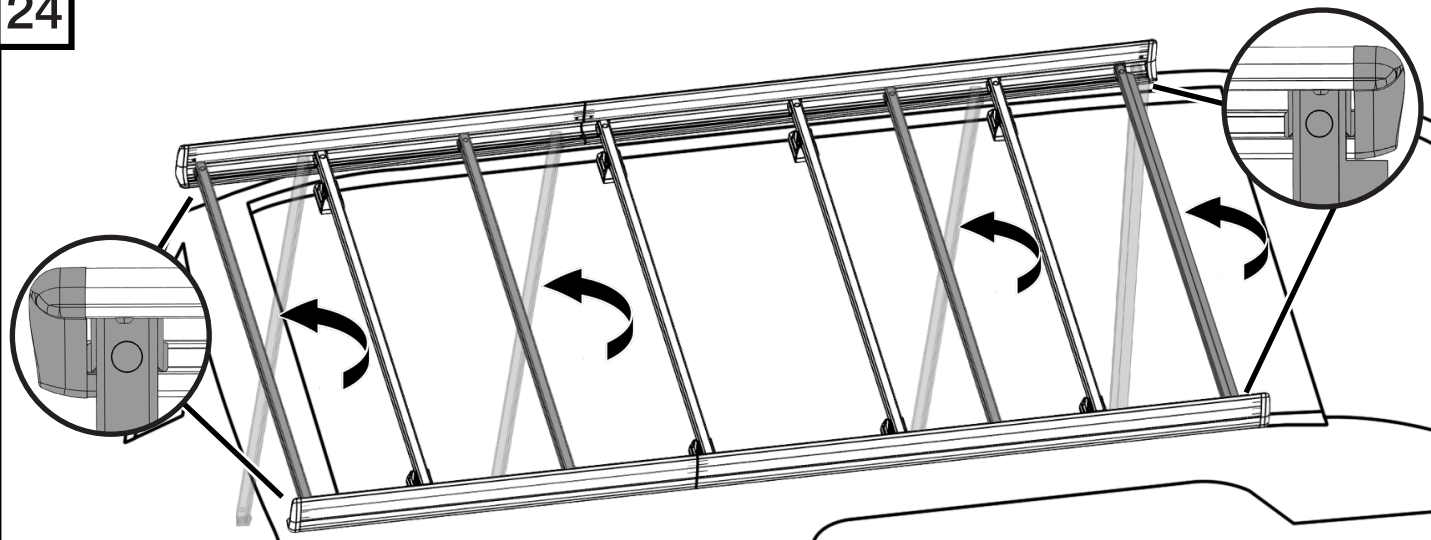

25

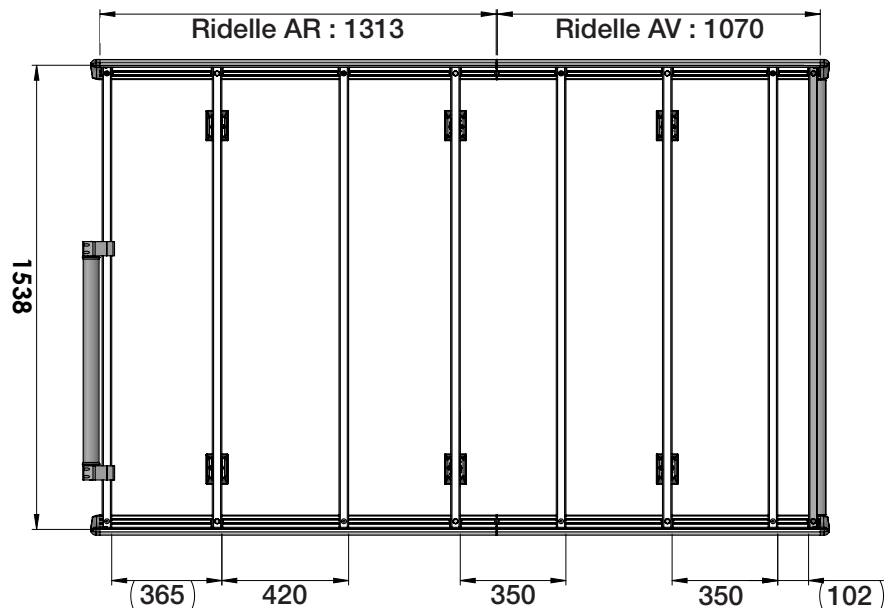

AR

AV

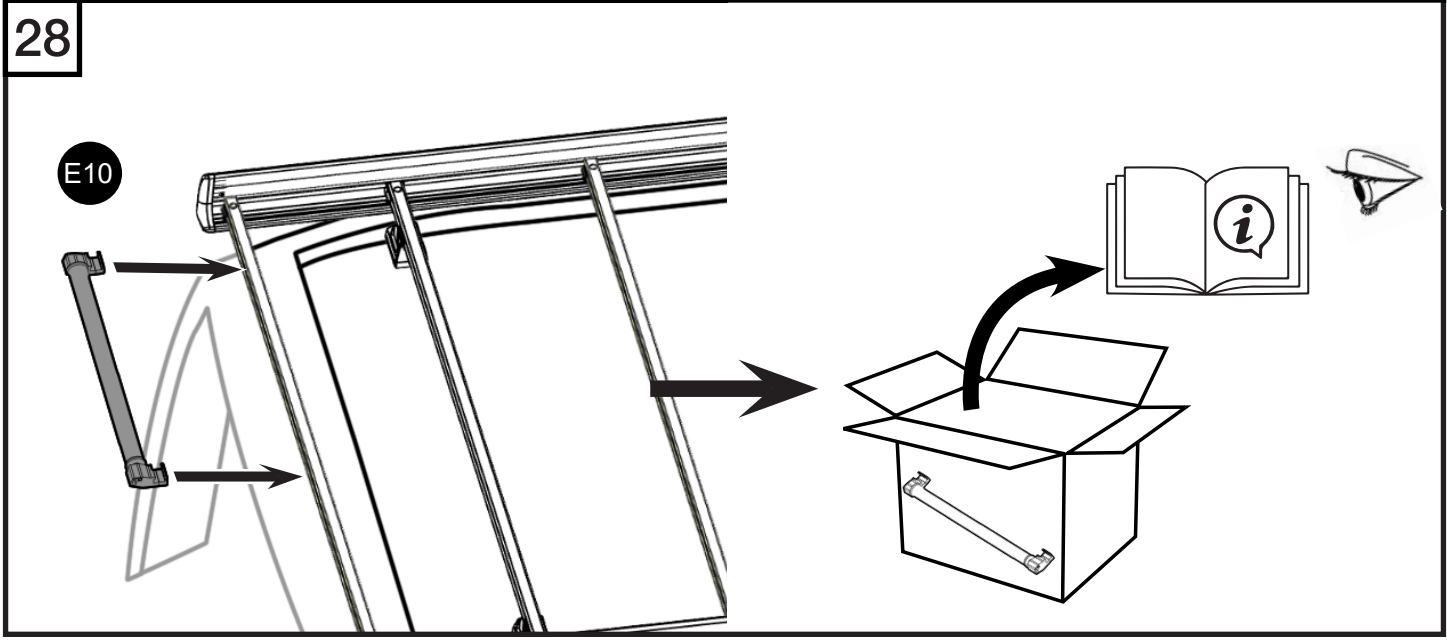
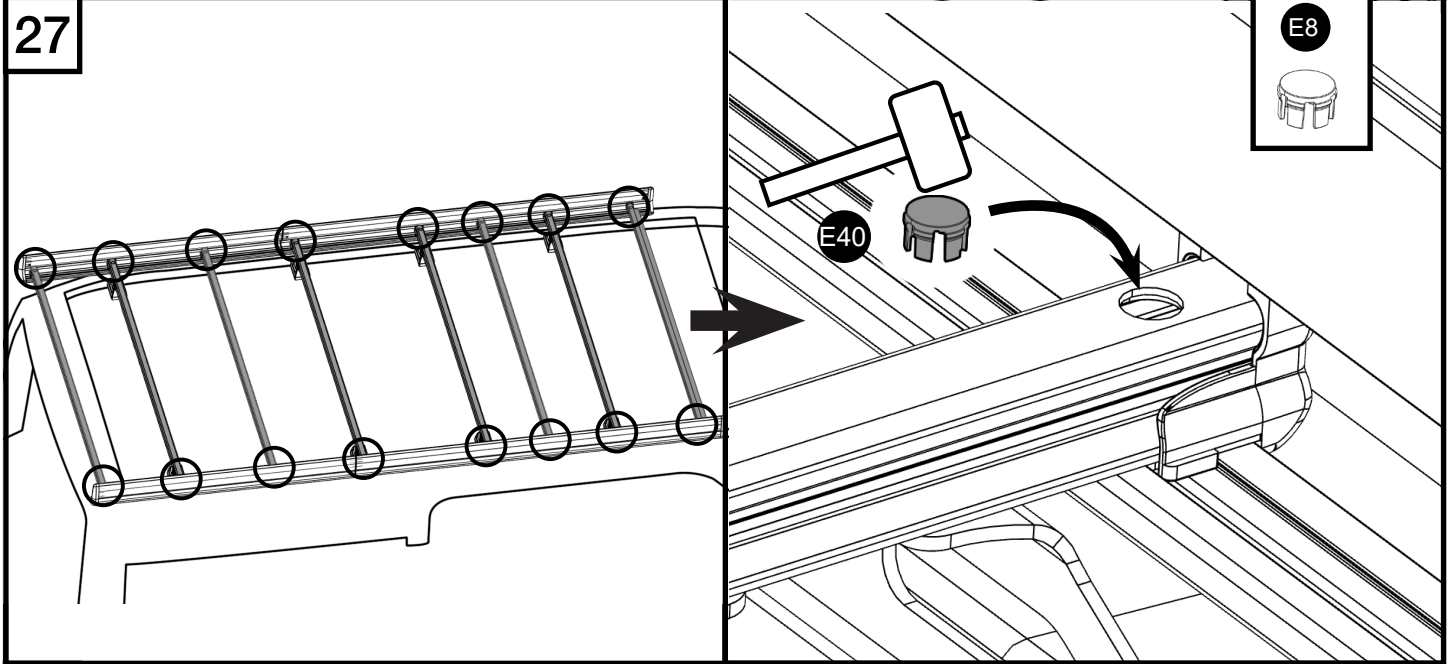
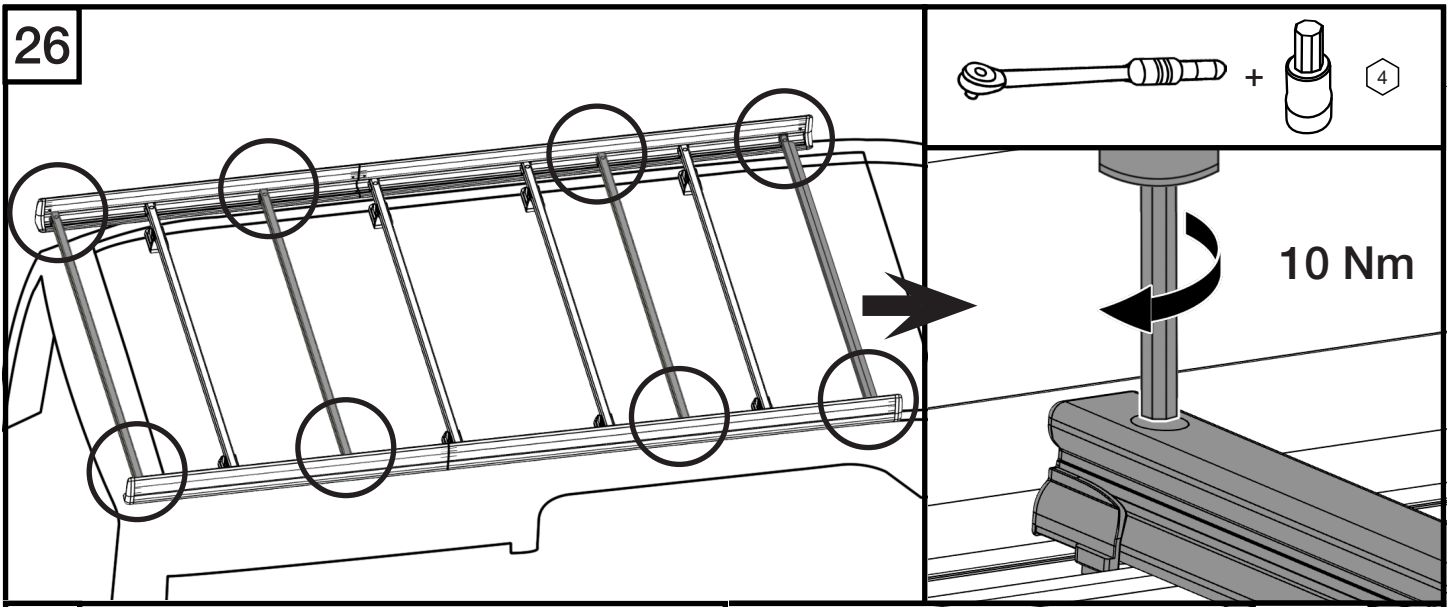



Max **130** Km/h

Max **80** Miles/h

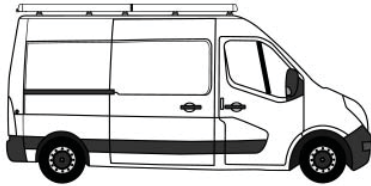
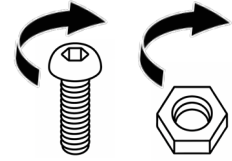
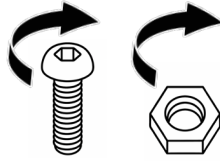

500 Km

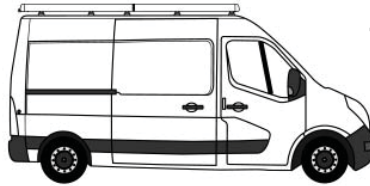

1000 Km

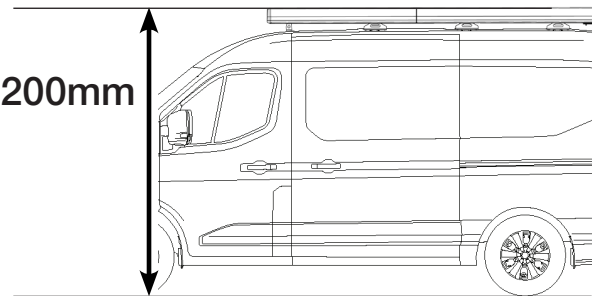
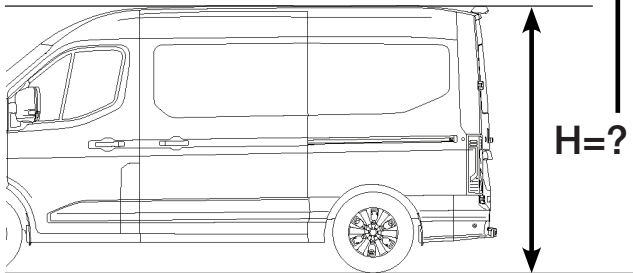
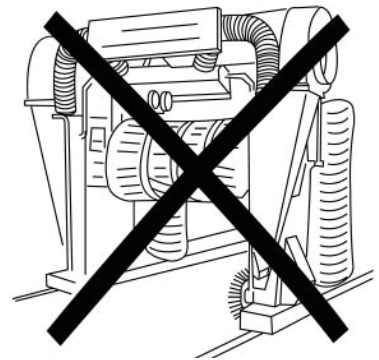
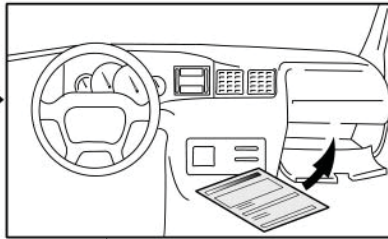
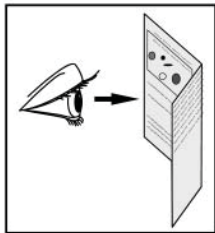
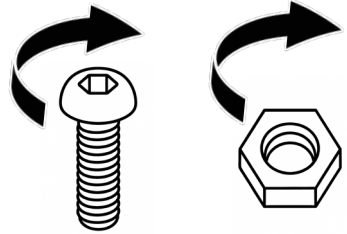
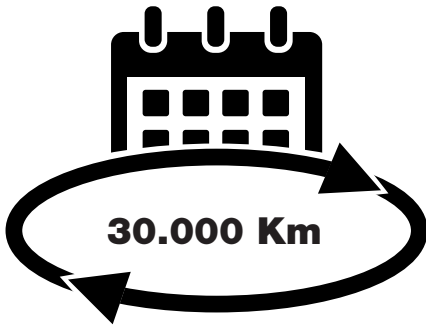
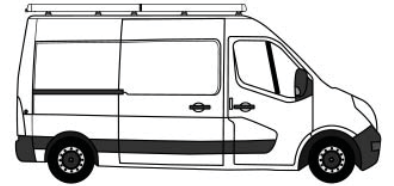

FR

Les instructions de montage et/ou d'utilisation prescrites par le constructeur, dans ce présent document, sont établies en fonction des spécifications techniques en vigueur à la date d'établissement du document. Elles sont susceptibles de modifications en cas de changements apportés par le constructeur à la fabrication des différents organes et accessoires des véhicules de sa marque. Ce produit ne doit pas être utilisé sur d'autres véhicules que ceux spécifiés par le constructeur. La sécurité est garantie si les instructions de montages et/ou d'utilisation sont respectées. Le non-respect de ces instructions et/ou la modification/réparation/entretien du produit en dehors de ces prescriptions, dégagent toute responsabilité du constructeur. Pour toutes questions, faites appel à un représentant de la marque

GB

The fitting and/or usage instructions given by the manufacturer in this document are based on the technical specifications current when the document was created. The instructions may be modified as a result of changes introduced by the manufacturer in the production of the various component units and accessories from which its vehicles are constructed.

This product should not be used on vehicles other than those specified by the manufacturer. Safety is guaranteed if the fitting and/or usage instructions are adhered to. If these instructions are not adhered to and/or the modification/repair/maintenance of the product is carried out in non-compliance with these instructions, the manufacturer is released from any responsibility. If you have any questions, contact a representative of the brand.

IT

Le istruzioni sul montaggio e/o l'utilizzo fornite dal produttore nel presente documento sono basate sulle caratteristiche tecniche presenti al momento della creazione del documento. Tali istruzioni sono soggette a modifiche qualora il costruttore apporti delle modifiche nella produzione dei diversi accessori e unità dei componenti dei veicoli.

Questo prodotto non deve essere utilizzato su veicoli diversi da quelli specificati dal costruttore. Se si rispettano le istruzioni sul montaggio e/o l'utilizzo, la sicurezza è garantita. In caso di mancata osservanza delle presenti istruzioni e/o di esecuzione di modifiche/riparazioni/manutenzione del prodotto non conformi alle istruzioni, il costruttore è sollevato da ogni responsabilità. In caso di domande, contattare un rappresentante del marchio.

ES

Las instrucciones de montaje y/o uso facilitadas por el fabricante en este documento se basan en las especificaciones técnicas vigentes en el momento de creación del documento. Las instrucciones pueden ser modificadas en caso de cambios efectuados por el fabricante en la producción de los diversos órganos y accesorios a partir de los cuales se fabrican sus vehículos.

Este producto no debe usarse en vehículos distintos a los especificados por el fabricante. La seguridad está garantizada siempre que se respeten las instrucciones de montaje y/o uso. Si estas instrucciones no se respetan y/o la modificación/repación/mantenimiento del producto se realiza sin seguir dichas instrucciones, el fabricante queda exento de toda responsabilidad. En caso de duda, ponerse en contacto con un representante de la marca.

PT

As instruções de montagem e/ou de utilização fornecidas pelo construtor incluídas neste documento são baseadas nas características técnicas no momento em que o documento foi criado. As instruções poderão ser modificadas em função de alterações introduzidas pelo construtor no fabrico dos diferentes órgãos e acessórios dos veículos.

Este produto não deve ser utilizado em veículos diferentes dos especificados pelo construtor. A segurança é garantida se as instruções de montagem e/ou de utilização forem respeitadas. Se estas instruções não forem respeitadas e/ou a modificação/repção/manutenção do produto não for realizada em conformidade com estas instruções, o construtor não assumirá qualquer responsabilidade. Em caso de dúvidas, contactar um representante da marca.

NL

De door de constructeur verstrekte montage- en/of gebruiksvorschriften, zoals in dit document beschreven, zijn gemaakt volgens de technische richtlijnen geldend op het tijdstip dat dit document werd samengesteld. Deze voorschriften zijn aan verandering onderhevig indien de constructeur tussentijds constructiewijzigingen op onderdelen of accessoires heeft aangebracht.

Dit product mag niet worden gebruikt op andere voertuigen dan dedoor de constructeur genoemde. De veiligheid wordt gegarandeerd wanneer de montage- en/of gebruiksvorschriften zijn nageleefd. Als deze voorschriften niet zijn nageleefd en/of wijziging/reparatie/onderhoud van het product niet is uitgevoerd volgens deze voorschriften, dan is de constructeur van zijn aansprakelijkheid ontheven. Neem bij vragen contact op met de vertegenwoordiger van het merk

DE

Die in diesem Dokument aufgeführten Montage- und/oder Bedienanleitungen des Herstellers basieren auf technischen Spezifikationen, die zum Zeitpunkt der Dokumenterstellung aktuell waren. Die Anleitungen können geändert werden, wenn der Hersteller verschiedene Komponenten oder Zubehörteile in seiner Fabrikation modifiziert.»

Dieses Produkt sollte nicht in anderen Fahrzeugen als den Fahrzeugen eingesetzt werden, die durch den Hersteller spezifiziert wurden. Sicherheit ist nur gewährleistet, wenn die Montage- und/oder Bedienungsanleitungen befolgt werden. Falls diese Anleitungen nicht befolgt werden und/oder die Modifikations-/Reparatur-/Wartungsmaßnahmen des Produkts abweichend von diesen Anleitungen vorgenommen werden, stellt dies einen Haftungsausschluss des Herstellers dar. Falls Sie hierzu Fragen haben sollten, nehmen Sie Kontakt mit Ihrem Markenrepräsentanten auf.

PL

Instrukcje montażu/obsługi zawarte przez producenta w tym dokumencie zostały oparte na danych technicznych aktualnych w momencie powstawania dokumentacji. Mogą one ulec zmianie w przypadku wprowadzenia przez producenta modyfikacji procesu produkcji różnych podzespołów i akcesoriów pojazdów tej marki.

Tego podzespołu nie można wykorzystywać w pojazdach innych niż określone przez producenta. Tylko przestrzeganie instrukcji montażu i obsługi gwarantuje odpowiednie bezpieczeństwo. W przypadku nieprzestrzegania instrukcji i/lub wykonania modyfikacji/napraw/konserwacji produktu w sposób niezgodny z niniejszymi instrukcjami, producent nie ponosi żadnej odpowiedzialności. W przypadku pytań należy skontaktować się z przedstawicielem marki.

DK

Udstyret og/eller vejledningen er leveret af producenten og baseret på de tekniske specifikationer, der var gældende på det tidspunkt, hvor dokumentet blev udfærdiget. Opdateringer til vejledningen kan forekomme som en følge af ændringer, som producenten sidenhen indfører i produktionen af komponenter og tilbehør til køretøjerne.

Dette produkt bør ikke anvendes på andre køretøjer end de af producenten angivne. Såfremt udstyret og/eller vejledningen følges, er der garanti for sikkerhed. Hvis denne vejledning ikke følges og/eller ændring/reparation/vedligeholdelse af produktet ikke udføres i overensstemmelse med denne vejledning, er producenten fritaget for ethvert ansvar. Såfremt der skulle opstå spørgsmål, er du velkommen til at kontakte din Renault-repræsentant.