

MC5KR

KammRack

Instructions

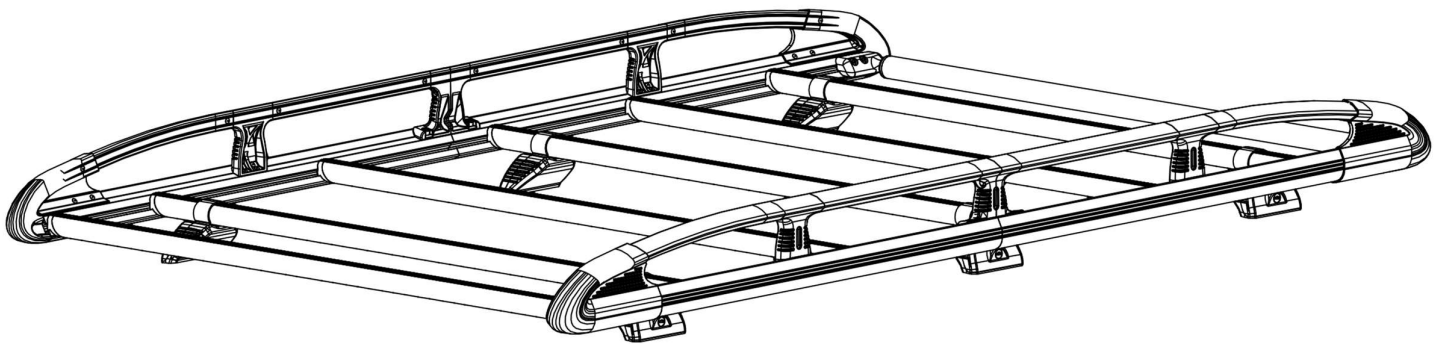

CITY CRASH (✓)

According to ISO/ PAS 11154:2006

MC5KR:

MERCEDES Sprinter 2006-
VW Crafter 2006-2017-
VW Crafter 2017-

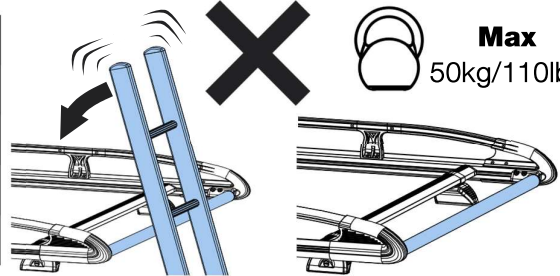
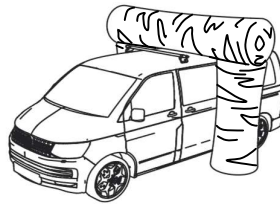
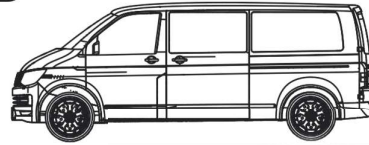

Max
50kg/110lbs

KammRack

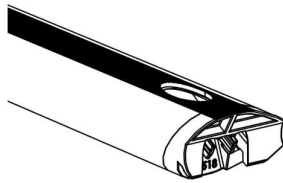

SA430

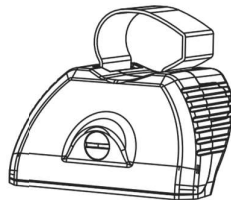

SA398U x 5

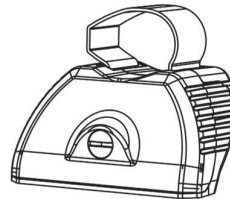

SA397U x 5



C04 x 10
optional upgrade

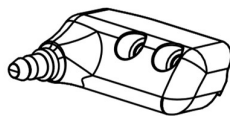

PS519 x 1

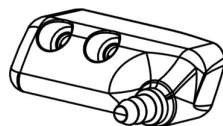

PS520 x 1

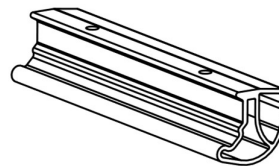

EXT15-02

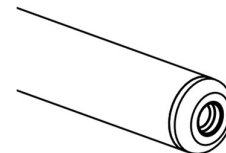

SA438 x 1

LHS x 2

RHS x 2

Centre

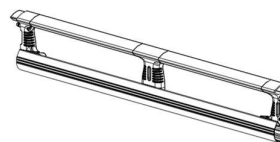
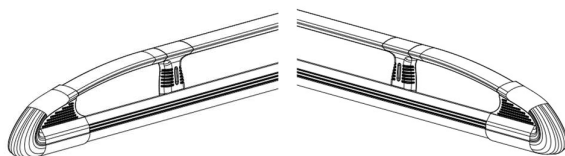

ASF x 1

Fitting Kit

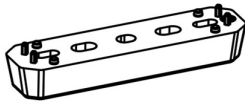

PS183 x 10

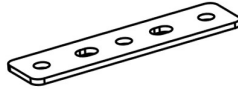

PS023 x 10

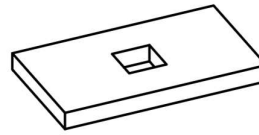

MS209 x 20

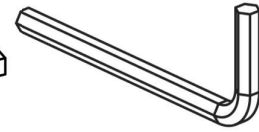

FT01 x 1

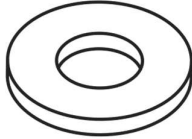

FW002 (M8) x 10



FN006 (M8) x 20

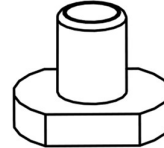

FN085 x 26



PS020 x 10



FS018
(M8 x 25) x 26

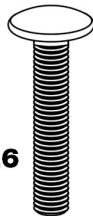

FS134
(M8 x 45) x 20

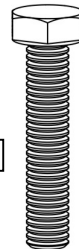

FS081
(M8 x 50) x 10

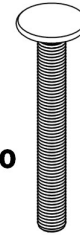

FS293
(M8 x 65) x 20



FS107
(M8 x 75) x 10

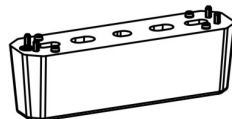

PS325 x 10



FT05 x 1

K521- Sprinter/Crafter 2006- L3, H2, Twin Doors

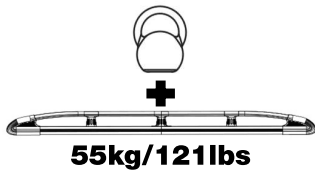

**150kg
Max**

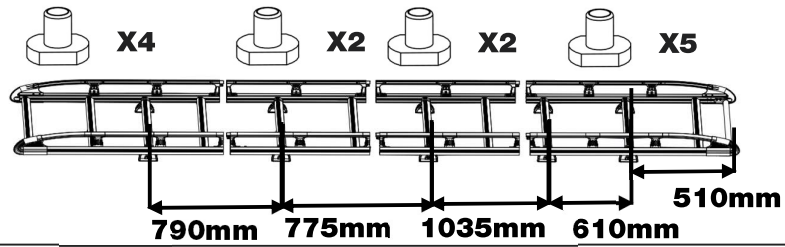
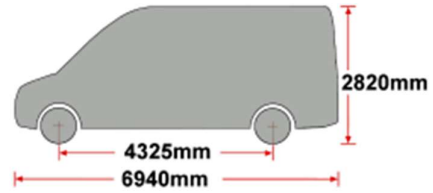

A

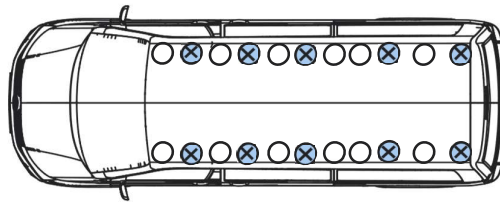

K522- Sprinter/Crafter 2006- L4, H2, Twin Doors

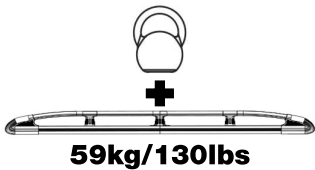

**150kg
Max**

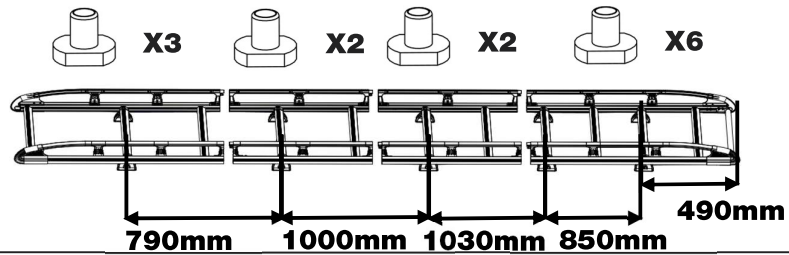
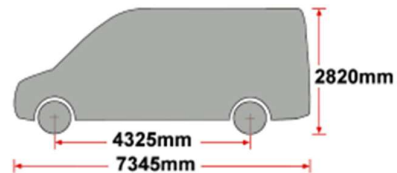

B

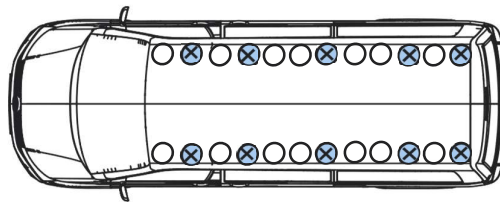

1. **A+B**

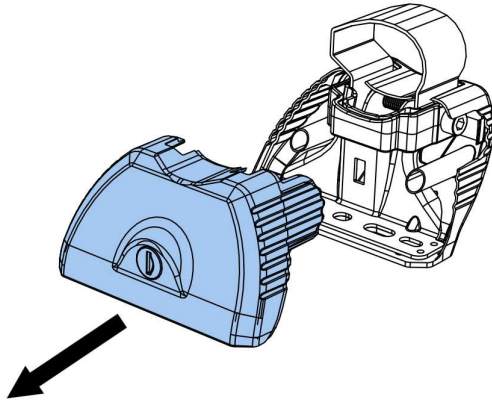

2.

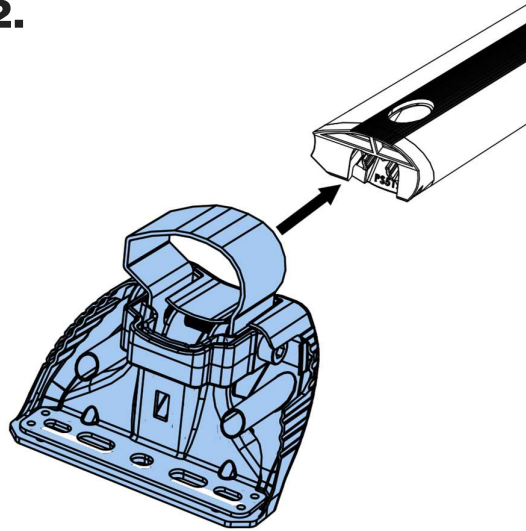

3.



**SA397U
PS183/PS325**

**SA397U
PS183/PS325**

**SA397U
PS183/PS325**

**SA397U
PS183/PS325**

**SA397U
PS183/PS325**

R

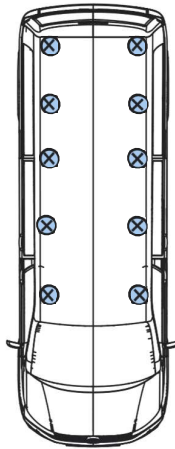

F

**SA398U
PS183/PS325**

**SA398U
PS183/PS325**

**SA398U
PS183/PS325**

**SA398U
PS183/PS325**

**SA398U
PS183/PS325**



4.

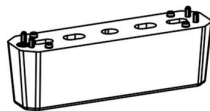

PS325

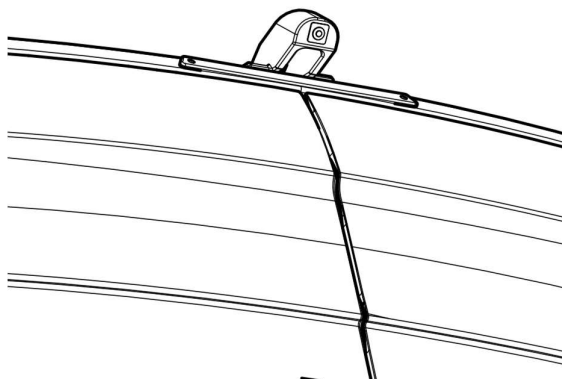

5.

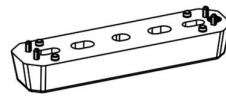

PS183

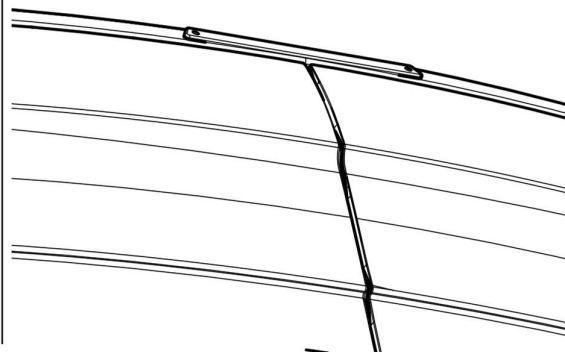

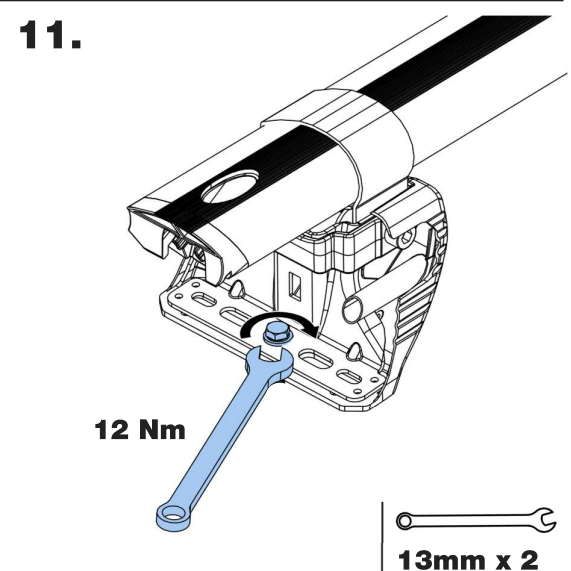
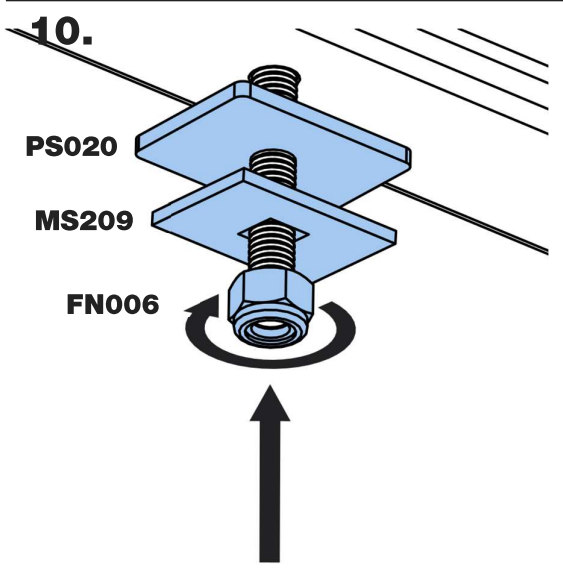
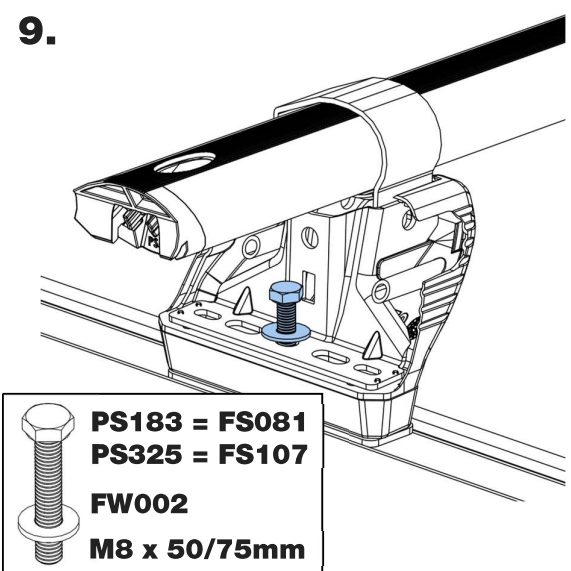
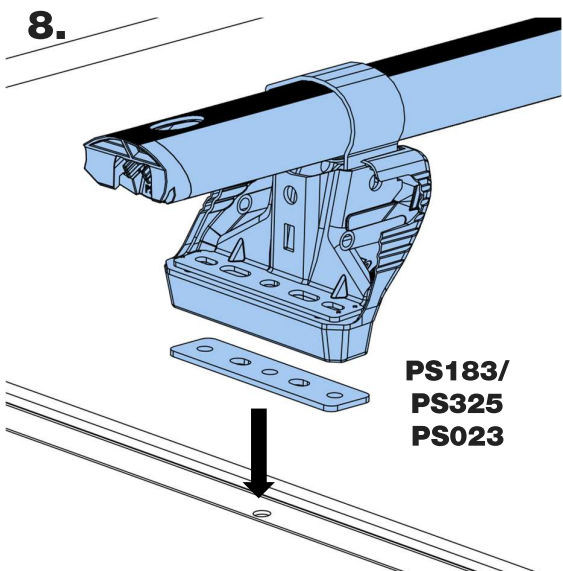
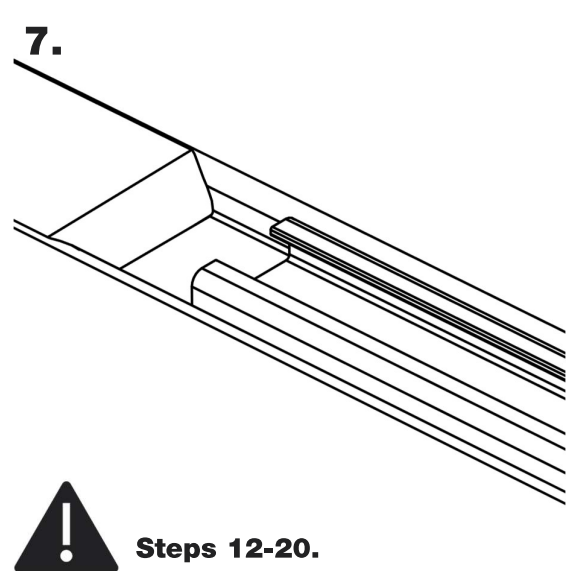
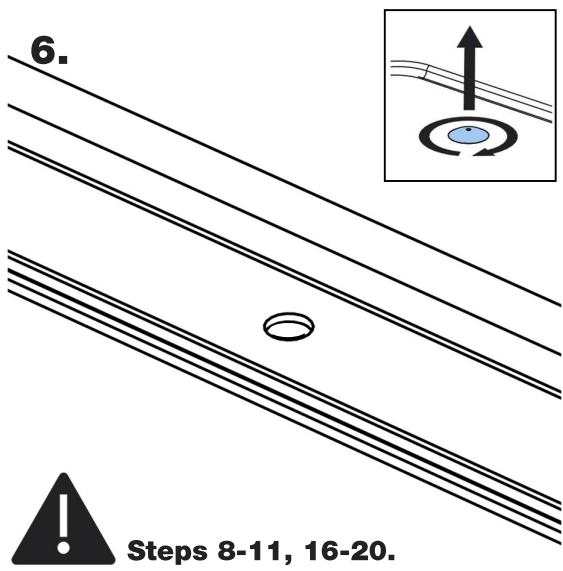

12.

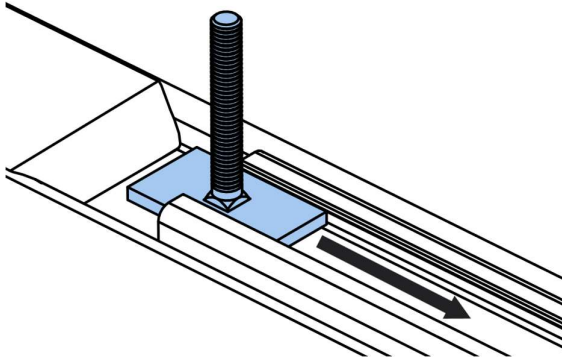
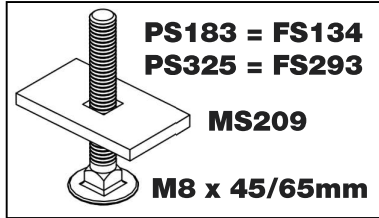

13.

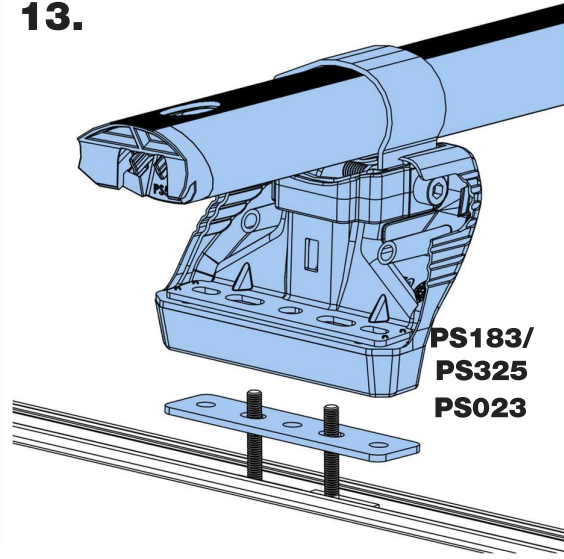

14.

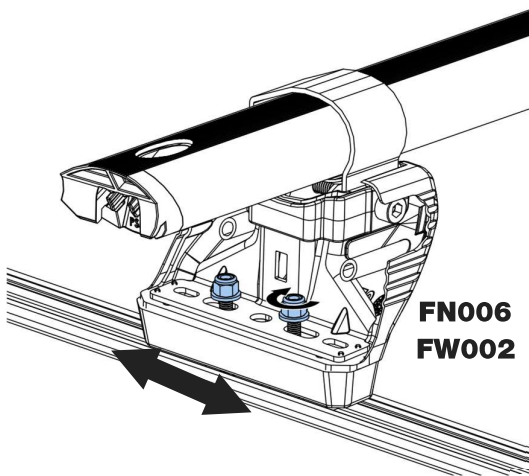

15.

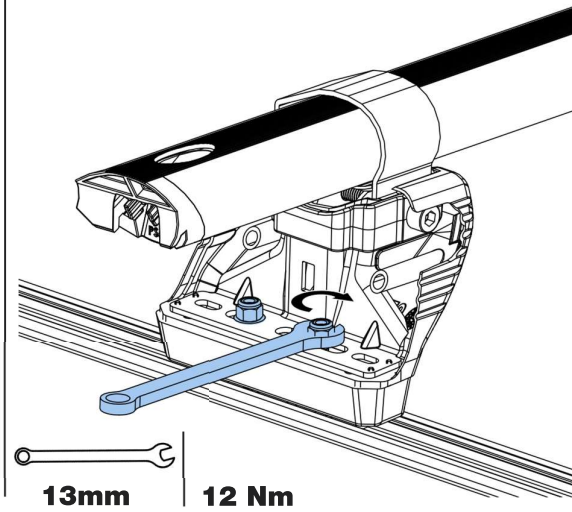

16.

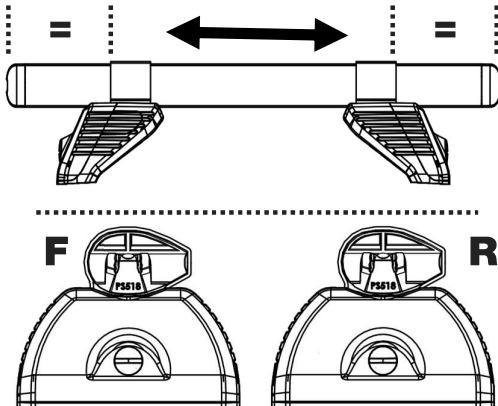

17.

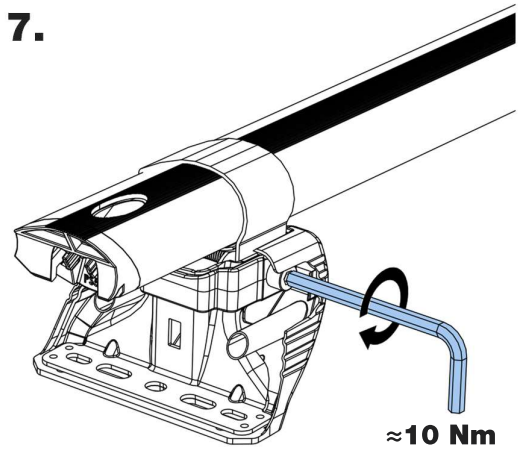

18.

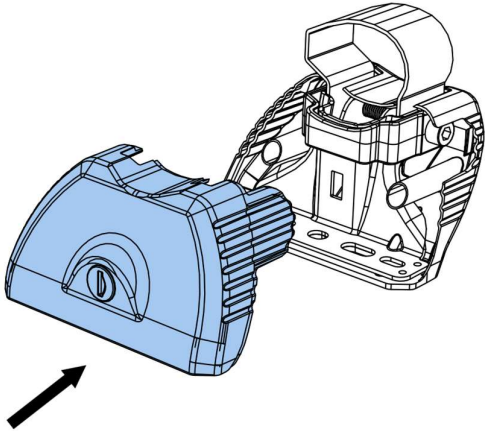

19.

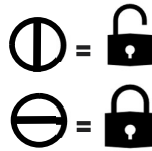
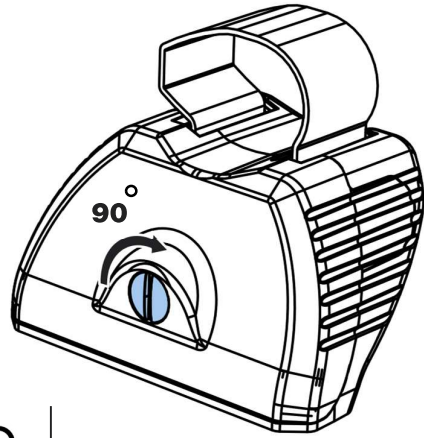

20.

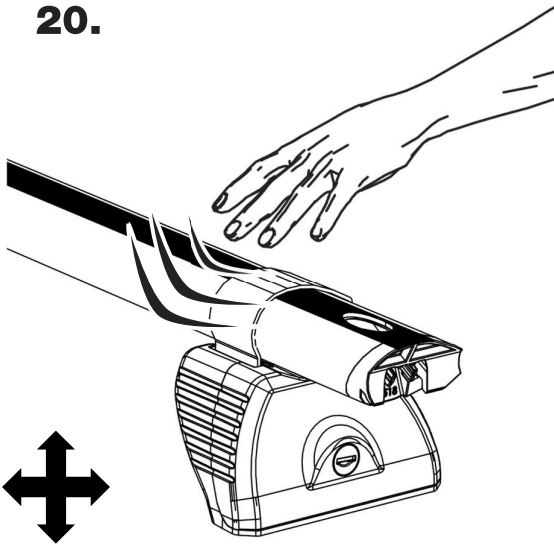

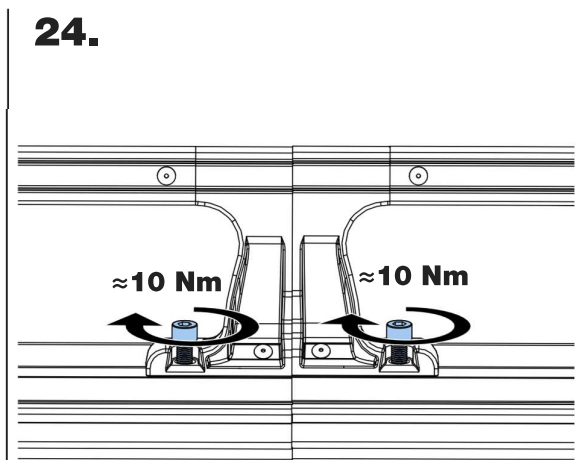
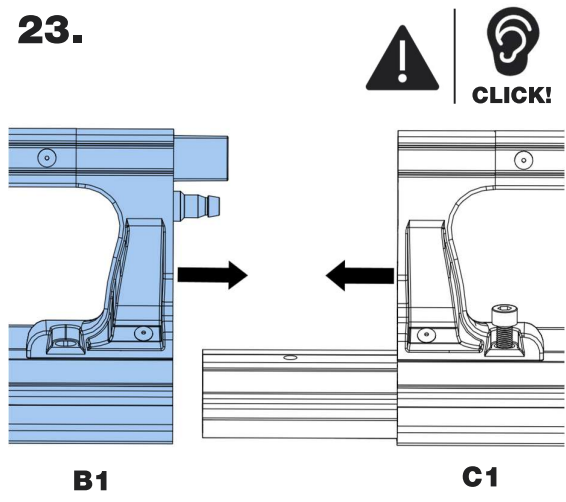
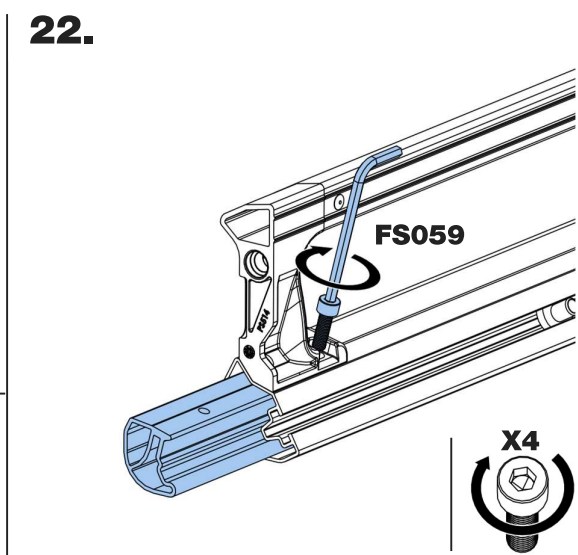
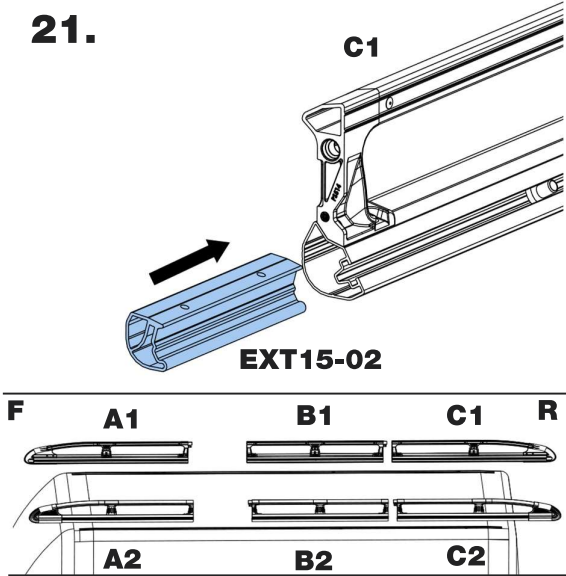
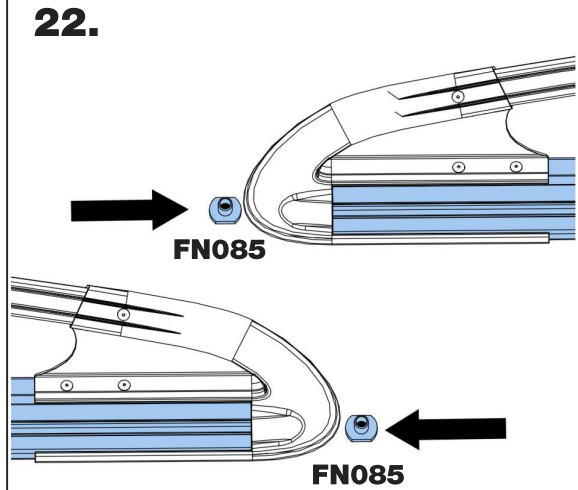
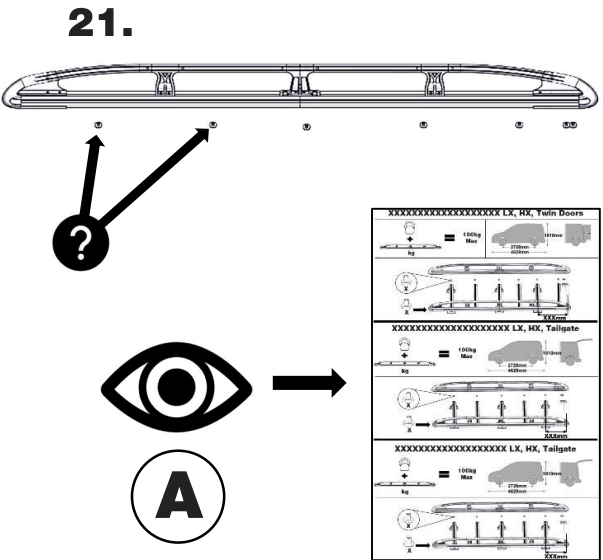

25.

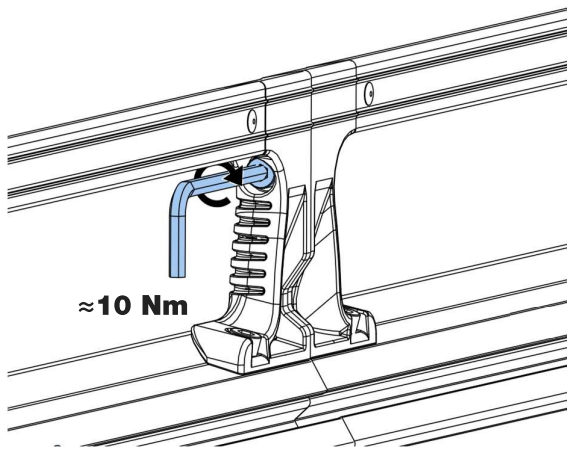

26.

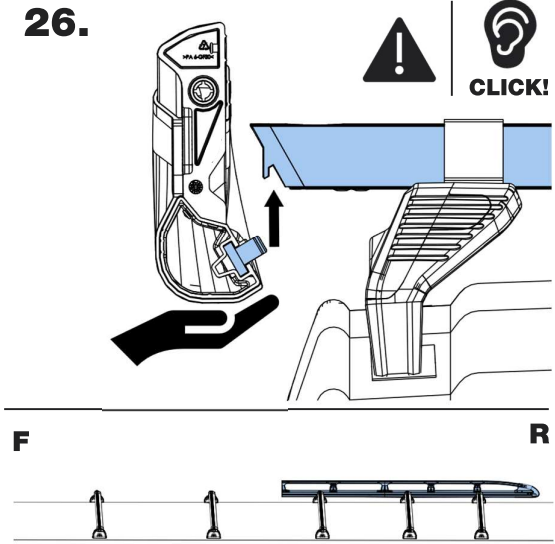

27.

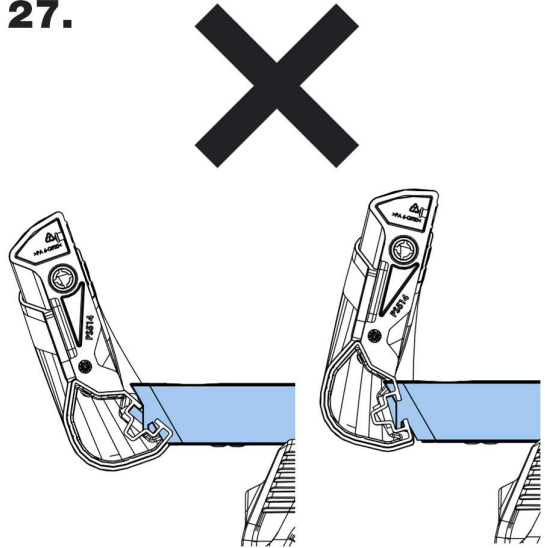

29.

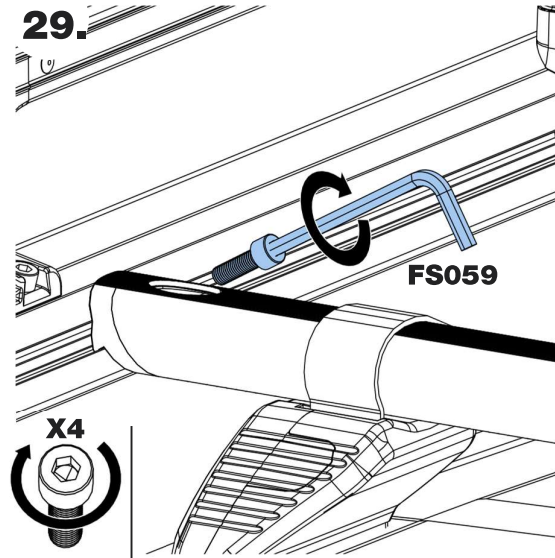

30.

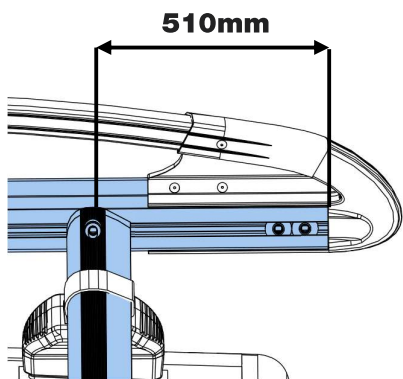

31.

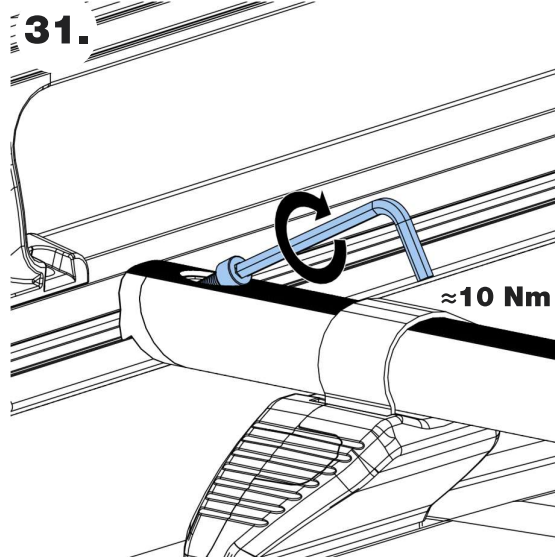

32.

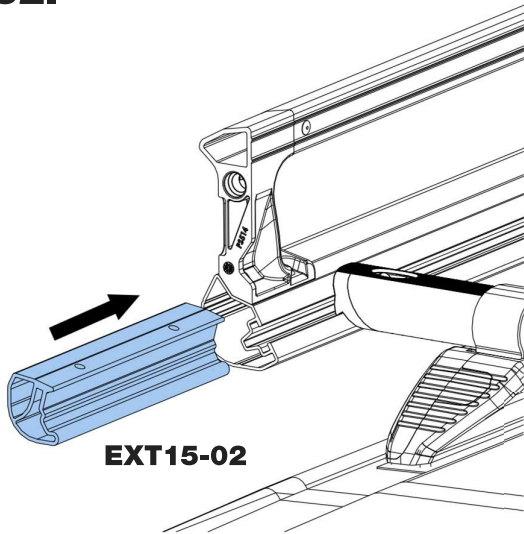

33.

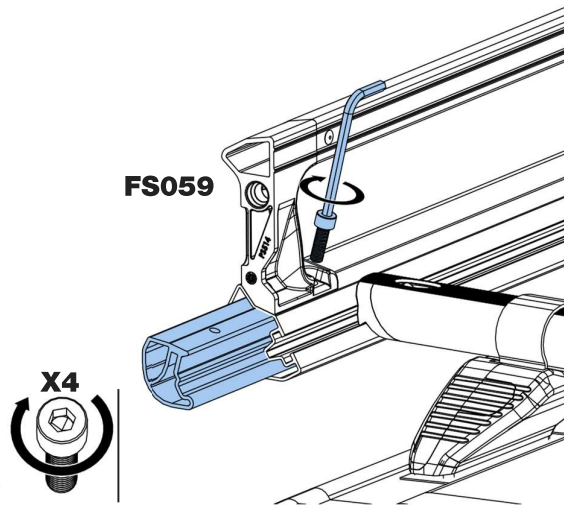

34.

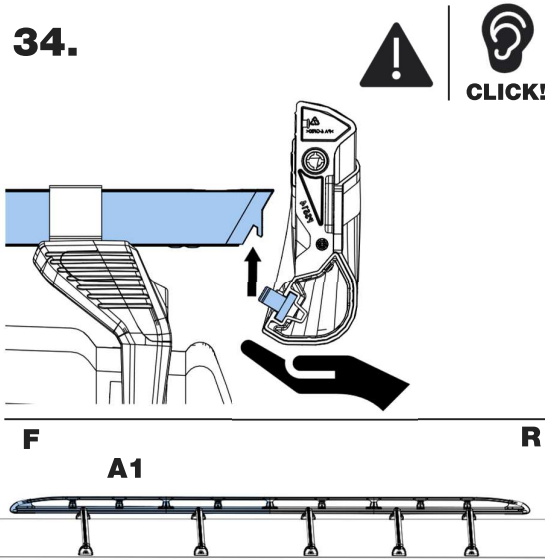

35.

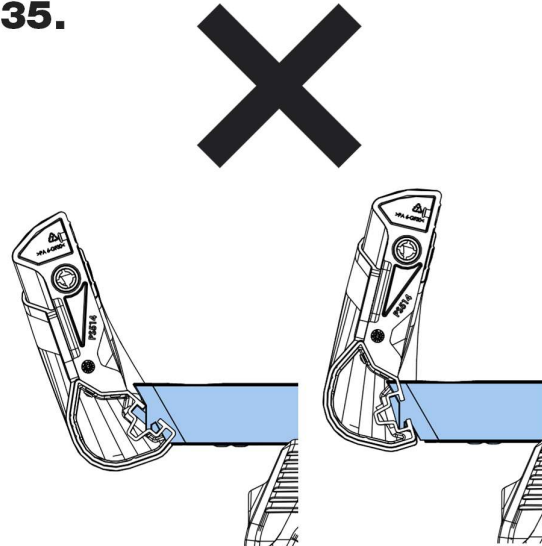

36.

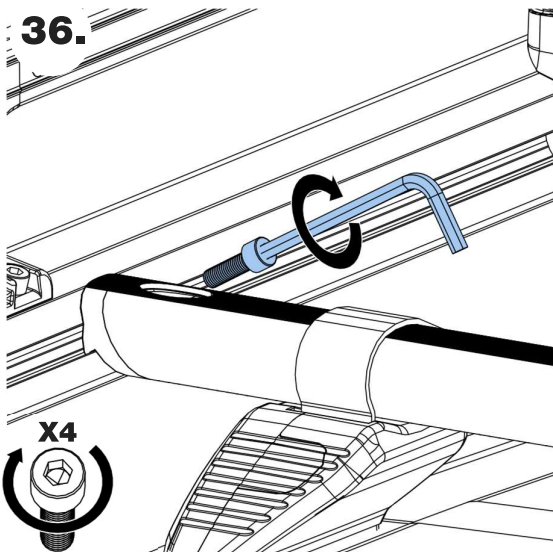

37.

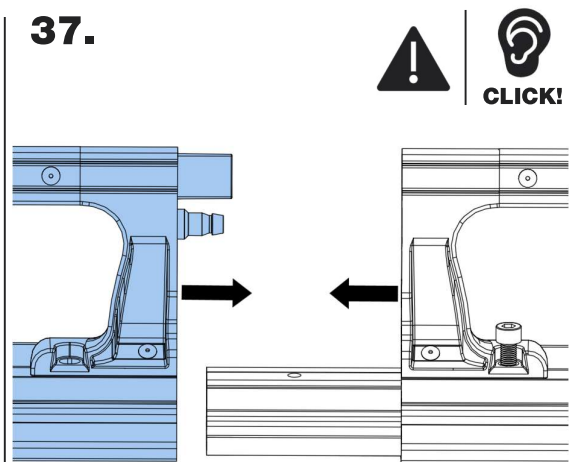

38.

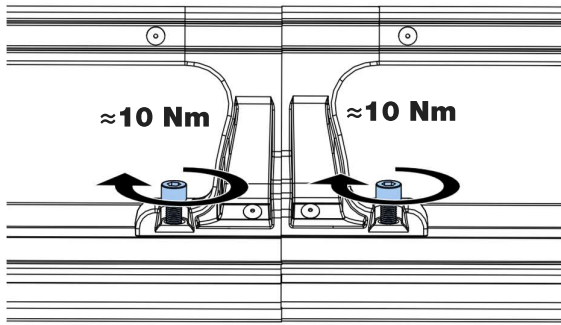

39.

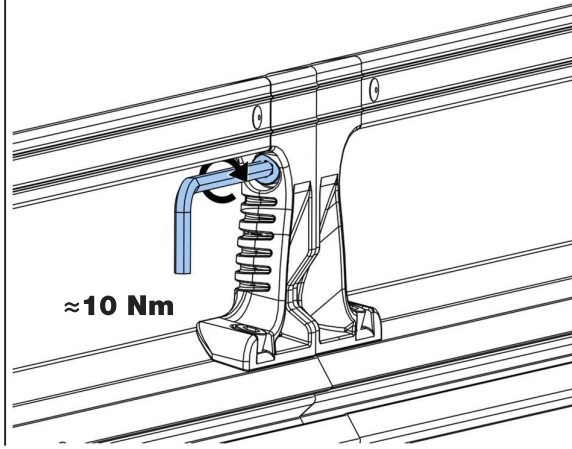

40.

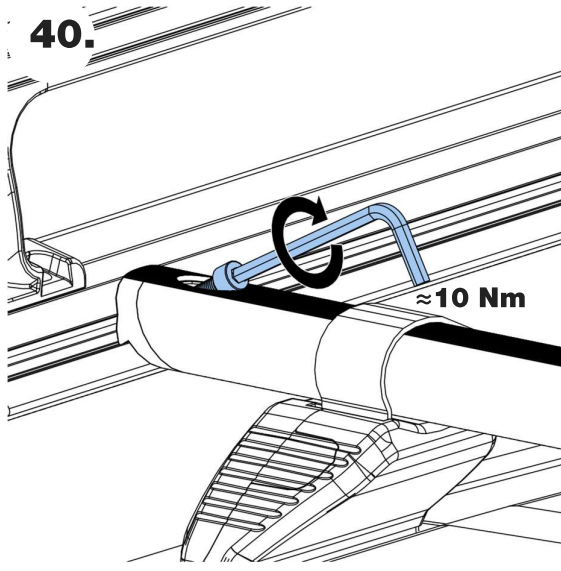

41.

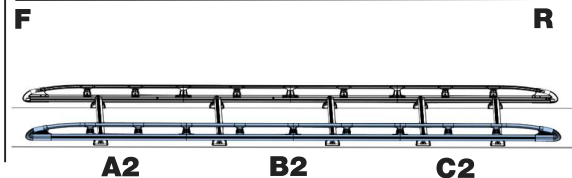
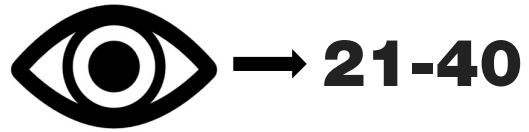

42.

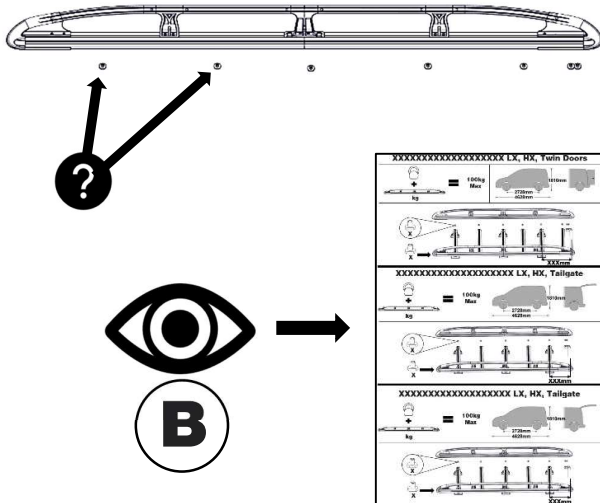

43.

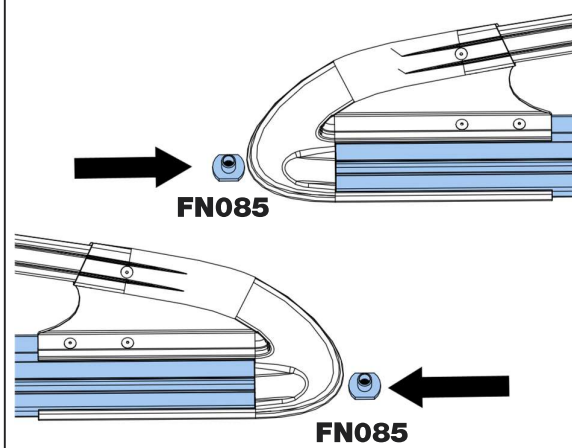

44.

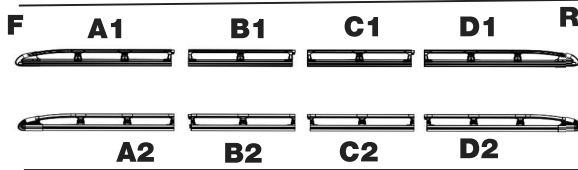
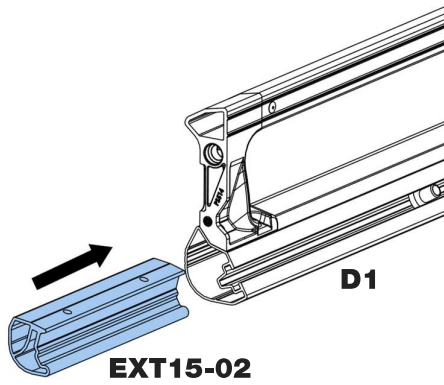

45.

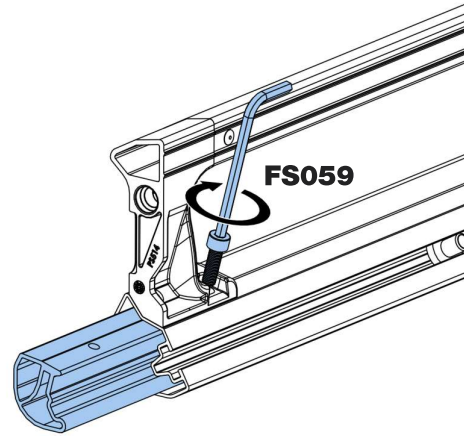

46.

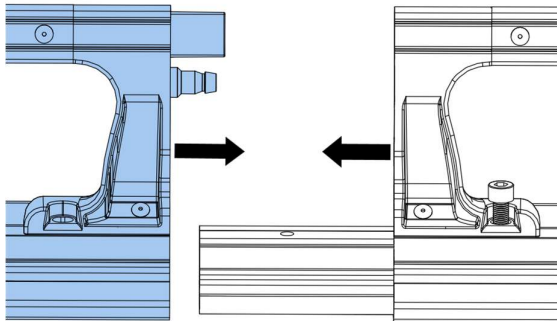

C1

D1

47.

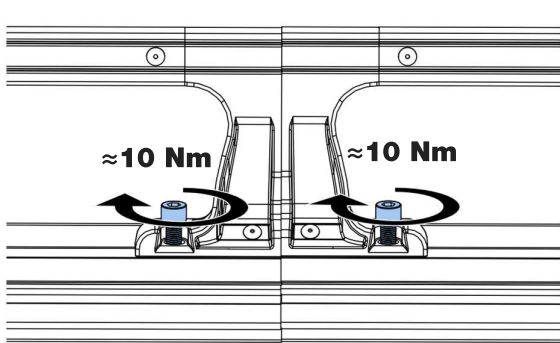

48.

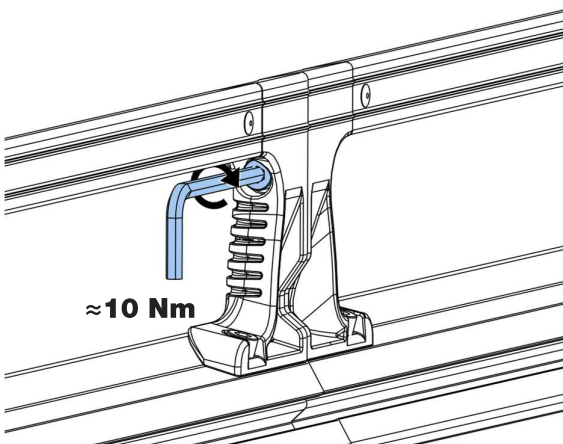

≈ 10 Nm

49.

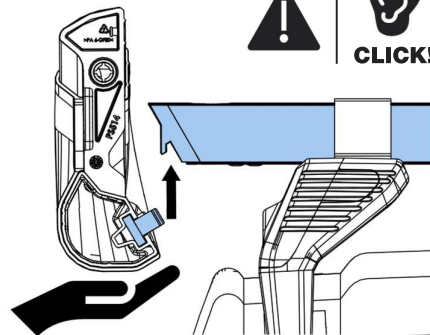

F

R



50.

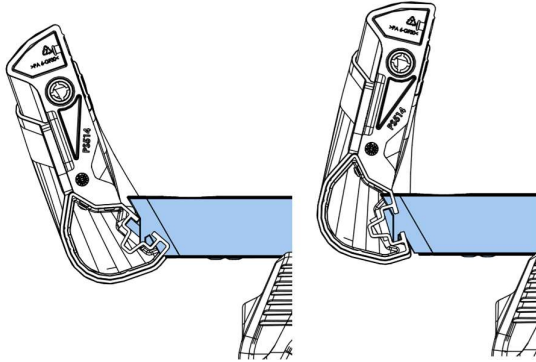

51.

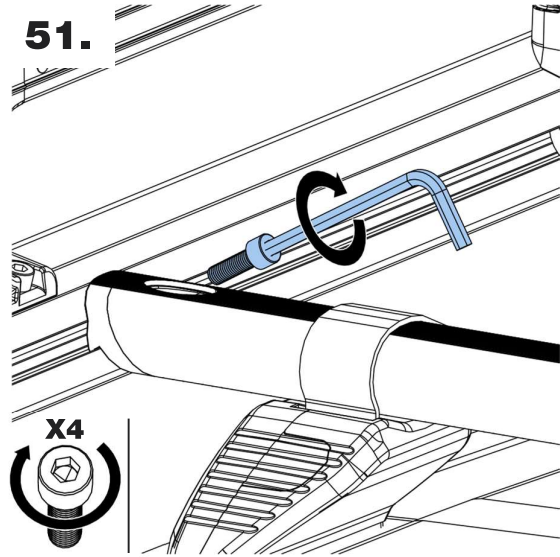

52.

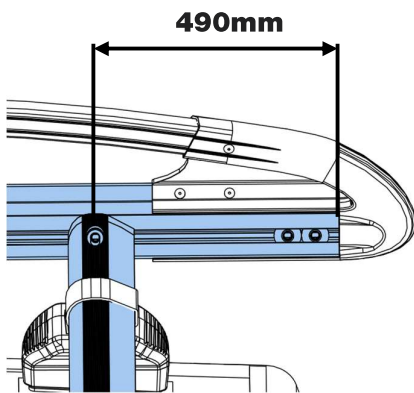

53.

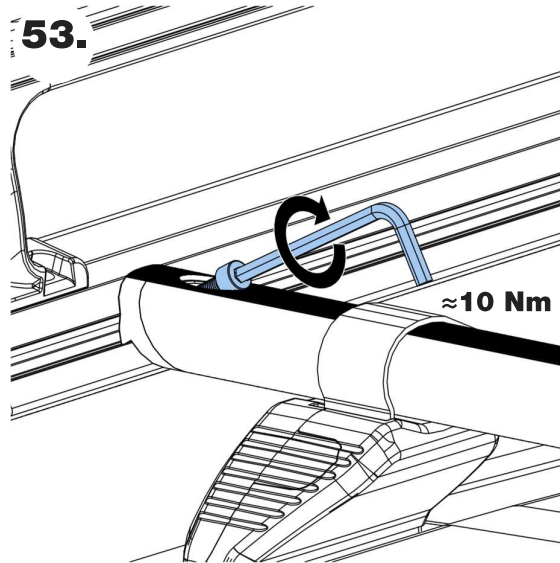

54.

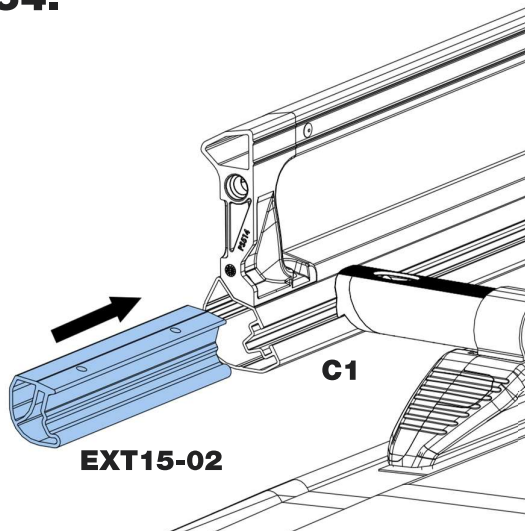

55.

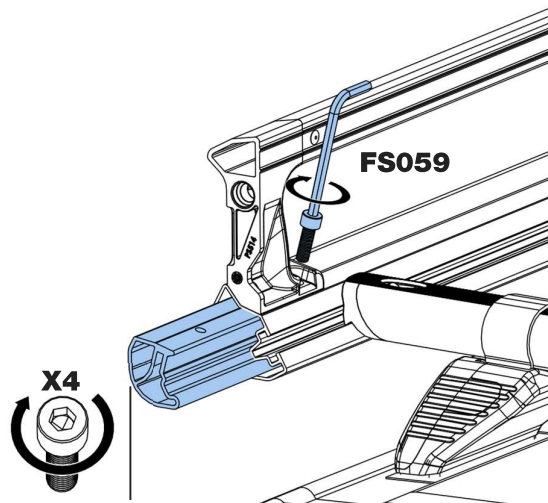

56.

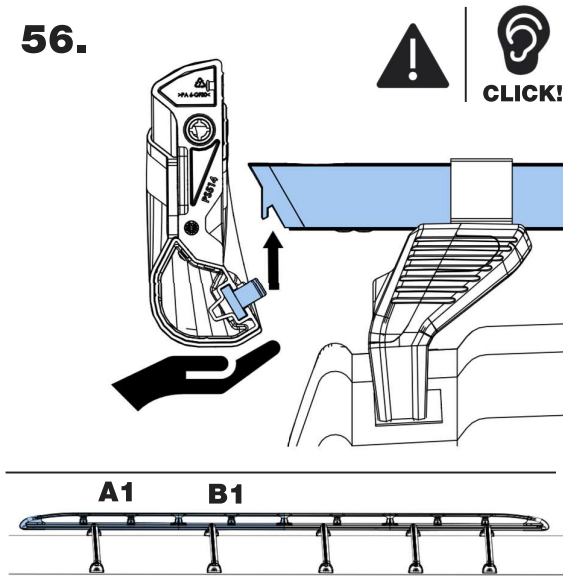

57.

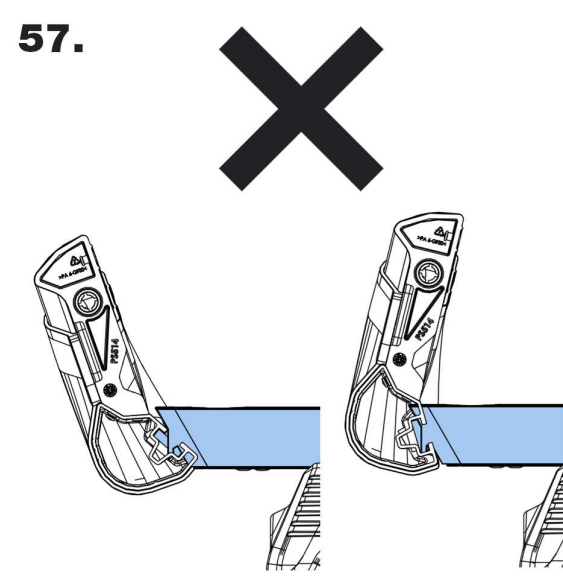

58.

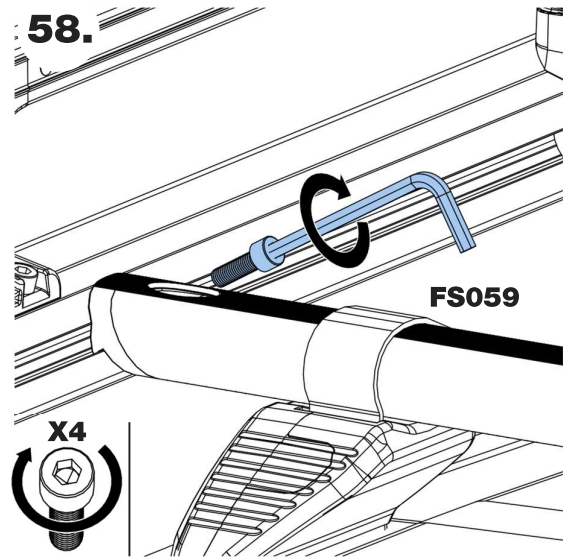

59.

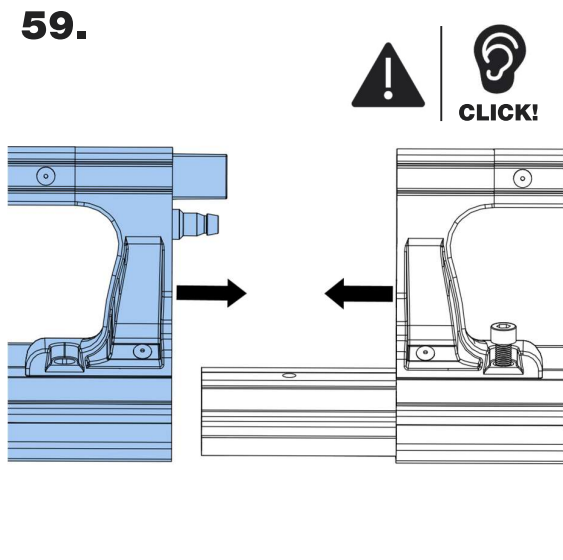

60.

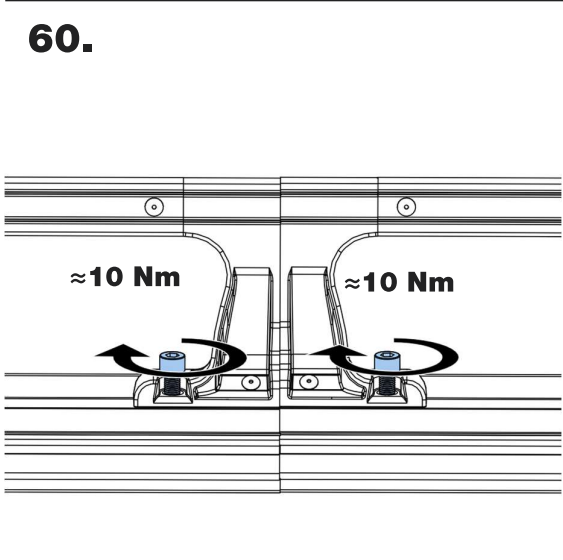

61.

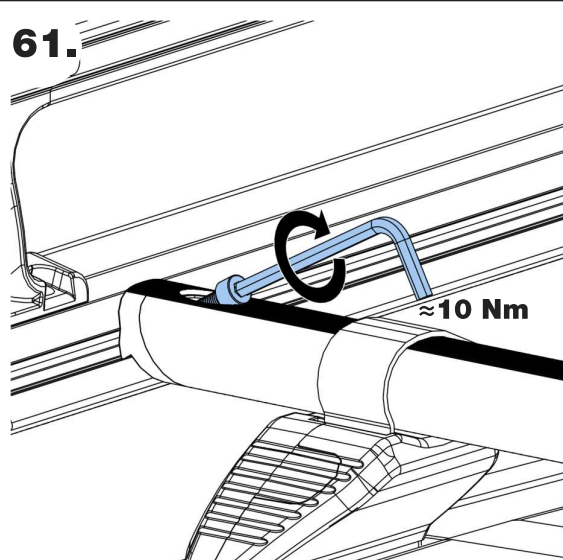

62.

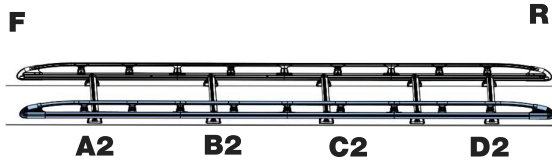
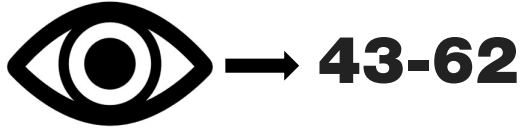

63.

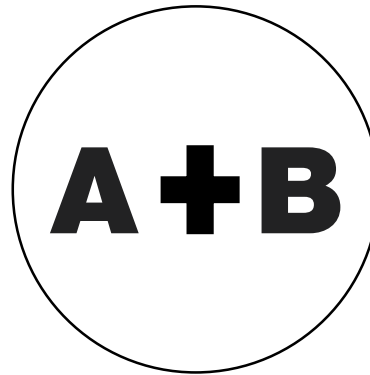

64.

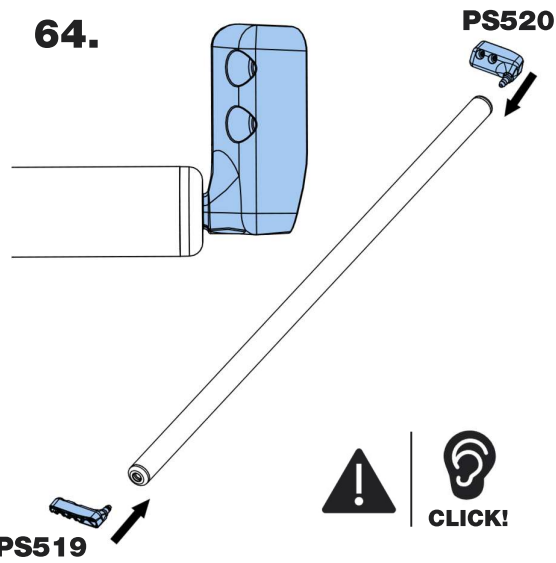

65.

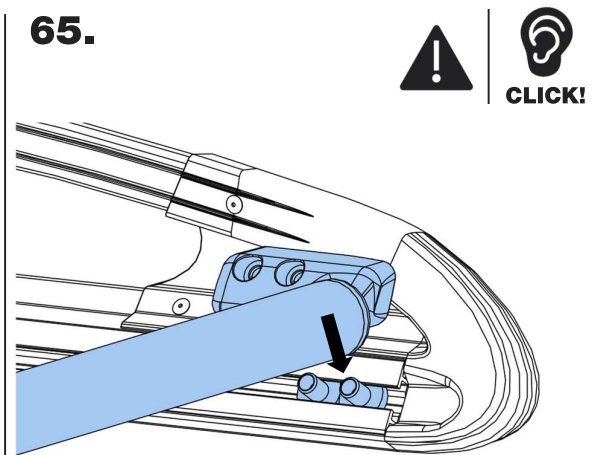

66.

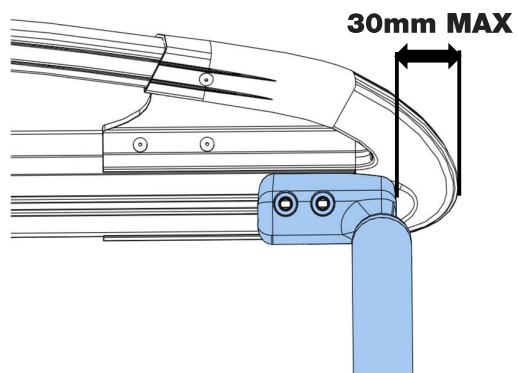

67.

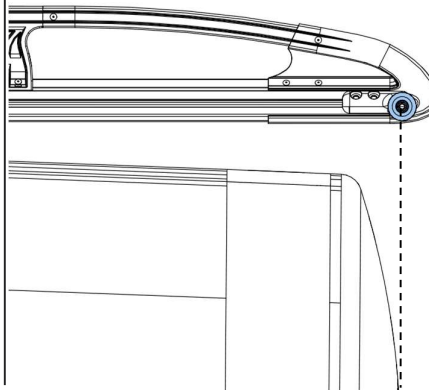

68.

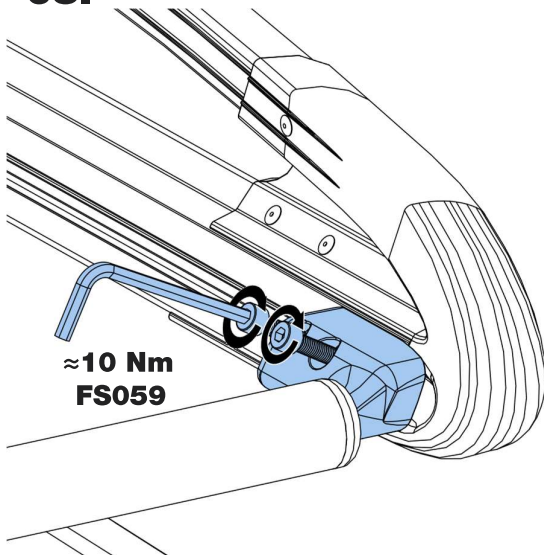

69.

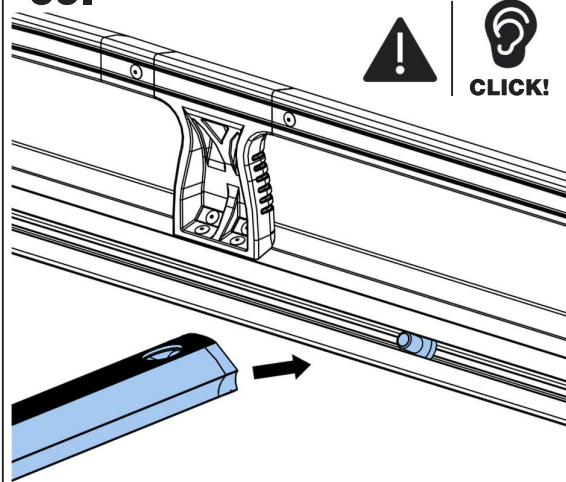

70.

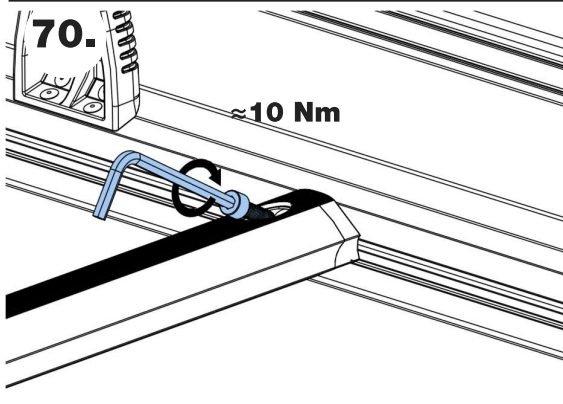

71.

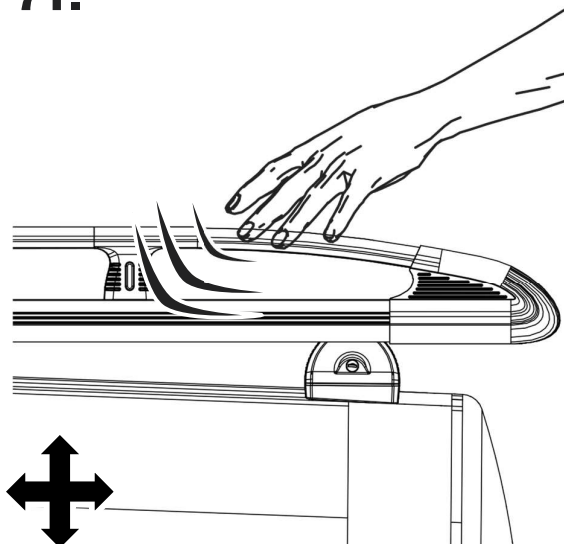

72.

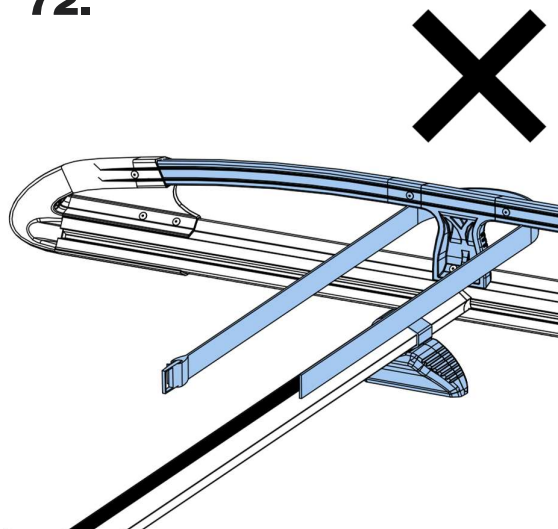

73.

